

INTERNATIONAL STANDARD

**Semiconductor devices – Semiconductor devices for energy harvesting and generation –
Part 8: Test and evaluation methods of flexible and stretchable supercapacitors
for use in low power electronics**

IECNORM.COM : Click to view the full PDF of IEC 62830-8:2021



THIS PUBLICATION IS COPYRIGHT PROTECTED
Copyright © 2021 IEC, Geneva, Switzerland

All rights reserved. Unless otherwise specified, no part of this publication may be reproduced or utilized in any form or by any means, electronic or mechanical, including photocopying and microfilm, without permission in writing from either IEC or IEC's member National Committee in the country of the requester. If you have any questions about IEC copyright or have an enquiry about obtaining additional rights to this publication, please contact the address below or your local IEC member National Committee for further information.

IEC Central Office
3, rue de Varembe
CH-1211 Geneva 20
Switzerland

Tel.: +41 22 919 02 11
info@iec.ch
www.iec.ch

About the IEC

The International Electrotechnical Commission (IEC) is the leading global organization that prepares and publishes International Standards for all electrical, electronic and related technologies.

About IEC publications

The technical content of IEC publications is kept under constant review by the IEC. Please make sure that you have the latest edition, a corrigendum or an amendment might have been published.

IEC publications search - webstore.iec.ch/advsearchform

The advanced search enables to find IEC publications by a variety of criteria (reference number, text, technical committee, ...). It also gives information on projects, replaced and withdrawn publications.

IEC Just Published - webstore.iec.ch/justpublished

Stay up to date on all new IEC publications. Just Published details all new publications released. Available online and once a month by email.

IEC Customer Service Centre - webstore.iec.ch/csc

If you wish to give us your feedback on this publication or need further assistance, please contact the Customer Service Centre: sales@iec.ch.

IEC online collection - oc.iec.ch

Discover our powerful search engine and read freely all the publications previews. With a subscription you will always have access to up to date content tailored to your needs.

Electropedia - www.electropedia.org

The world's leading online dictionary on electrotechnology, containing more than 22 000 terminological entries in English and French, with equivalent terms in 18 additional languages. Also known as the International Electrotechnical Vocabulary (IEV) online.

IECNORM.COM : Click to view the full text of IEC 61830-2:2021

INTERNATIONAL STANDARD

**Semiconductor devices – Semiconductor devices for energy harvesting and generation –
Part 8: Test and evaluation methods of flexible and stretchable supercapacitors
for use in low power electronics**

INTERNATIONAL
ELECTROTECHNICAL
COMMISSION

ICS 31.080.99

ISBN 978-2-8322-1040-1

Warning! Make sure that you obtained this publication from an authorized distributor.

CONTENTS

FOREWORD.....	4
1 Scope.....	6
2 Normative references	6
3 Terms and definitions	6
3.1 General terms	6
3.2 Characteristic parameters	10
4 Essential ratings and characteristic parameters.....	11
4.1 Identification and type.....	11
4.2 Limiting values and operating conditions.....	11
4.3 Additional information	12
5 Test method	12
5.1 General.....	12
5.1.1 General	12
5.1.2 Standard atmospheric conditions for test	13
5.1.3 Standard atmospheric conditions for measurement.....	13
5.2 Flat status.....	13
5.2.1 Measurement circuit	13
5.2.2 Measurement procedure	14
5.2.3 Essential parameters calculation	16
5.3 Bending status.....	18
5.3.1 General	18
5.3.2 Test procedure	19
5.4 Stretching status.....	22
5.4.1 General	22
5.4.2 Test procedure	23
6 Test reports.....	26
Annex A (informative) Classification of supercapacitors and its working principles.....	28
A.1 General.....	28
A.2 Classification	28
A.3 Working principles	28
A.3.1 Electrical double layer capacitor (EDLC).....	28
A.3.2 Pseudocapacitor.....	29
A.3.3 Hybrid supercapacitor.....	29
Annex B (informative) Endurance test (continuous application of rated voltage at low or high temperature)	30
B.1 General.....	30
B.2 Test method.....	30
B.2.1 Test conditions	30
B.2.2 Test procedure	30
B.2.3 Recommendations	30
Annex C (informative) Other bending testers.....	32
C.1 Bending stage using fixed and moving stage.....	32
C.2 Bending stage using rotating motor.....	32
Annex D (informative) Classification of flexible and stretchable supercapacitor.....	34
D.1 Flexible and stretchable supercapacitor with sandwich structure	34
D.2 Flexible and stretchable supercapacitor with in-planar structure.....	34
D.3 Flexible and stretchable supercapacitor with wire-shaped structure	34
D.4 Flexible textile made by using wire-shape supercapacitor	35

Bibliography.....	36
Figure 1 – Schematic of curvature radius	10
Figure 2 – Measurement procedure of flexible and stretchable supercapacitor	13
Figure 3 – Measurement circuit of flexible and stretchable supercapacitor	14
Figure 4 – Schematic illustration of the voltage-time (V-t) curve of the tested flexible and stretchable supercapacitor	15
Figure 5 – Schematic illustration of current-time (I-t) curve of the tested flexible and stretchable supercapacitor	15
Figure 6 – Schematic illustration of the voltage-current (V-I) curve of the tested flexible and stretchable supercapacitor	16
Figure 7 – Voltage-time curves during ten continuous charging-discharging processes of flexible and stretchable supercapacitor	17
Figure 8 – Calculated capacitance retention after certain number of repeated charging-discharging processes of flexible and stretchable supercapacitor	18
Figure 9 – Bending method of flexible and stretchable supercapacitor using bending stage ..	19
Figure 10 – Test setup for the performance reliability of flexible and stretchable supercapacitor under bending condition	20
Figure 11 – Comparison of charging-discharging curves with different curvature values of a flexible and stretchable supercapacitor	21
Figure 12 – Capacitance retention of flexible and stretchable supercapacitor under bending status	21
Figure 13 – Performance reliability of flexible and stretchable supercapacitor under bending status	22
Figure 14 – Stretching method of flexible and stretchable supercapacitor using stretching stage	23
Figure 15 – Test setup for the performance reliability of flexible and stretchable supercapacitor under stretching condition	24
Figure 16 – Comparison of charging-discharging processes of flexible and stretchable supercapacitor under various strain status	25
Figure 17 – Capacitance retention of flexible and stretchable supercapacitor under stretching status	25
Figure 18 – Reliability of flexible and stretchable supercapacitor under stretching status	26
Figure A.1 – Classification of supercapacitor according to its operation principles	28
Figure A.2 – Schematic illustration of the configuration of EDLC	28
Figure A.3 – Schematic illustration of the configuration of pseudocapacitor	29
Figure A.4 – Schematic illustration of the configuration of asymmetric hybrid supercapacitor	29
Figure C.1 – Bending stage using fixed and moving stage	32
Figure C.2 – Bending stage using rotating motor	33
Figure D.1 – Flexible and stretchable supercapacitor with sandwich structure	34
Figure D.2 – Flexible and stretchable supercapacitor with in-planar interdigital structured electrodes	34
Figure D.3 – Flexible and stretchable supercapacitor with wire-shaped structure	35
Figure D.4 – Flexible and stretchable supercapacitor with textile structure	35
Table 1 – Table of specification parameters for flexible and stretchable supercapacitor	12

INTERNATIONAL ELECTROTECHNICAL COMMISSION

**SEMICONDUCTOR DEVICES –
SEMICONDUCTOR DEVICES FOR ENERGY
HARVESTING AND GENERATION –**

**Part 8: Test and evaluation methods of flexible and stretchable
supercapacitors for use in low power electronics**

FOREWORD

- 1) The International Electrotechnical Commission (IEC) is a worldwide organization for standardization comprising all national electrotechnical committees (IEC National Committees). The object of IEC is to promote international co-operation on all questions concerning standardization in the electrical and electronic fields. To this end and in addition to other activities, IEC publishes International Standards, Technical Specifications, Technical Reports, Publicly Available Specifications (PAS) and Guides (hereafter referred to as "IEC Publication(s)"). Their preparation is entrusted to technical committees; any IEC National Committee interested in the subject dealt with may participate in this preparatory work. International, governmental and non-governmental organizations liaising with the IEC also participate in this preparation. IEC collaborates closely with the International Organization for Standardization (ISO) in accordance with conditions determined by agreement between the two organizations.
- 2) The formal decisions or agreements of IEC on technical matters express, as nearly as possible, an international consensus of opinion on the relevant subjects since each technical committee has representation from all interested IEC National Committees.
- 3) IEC Publications have the form of recommendations for international use and are accepted by IEC National Committees in that sense. While all reasonable efforts are made to ensure that the technical content of IEC Publications is accurate, IEC cannot be held responsible for the way in which they are used or for any misinterpretation by any end user.
- 4) In order to promote international uniformity, IEC National Committees undertake to apply IEC Publications transparently to the maximum extent possible in their national and regional publications. Any divergence between any IEC Publication and the corresponding national or regional publication shall be clearly indicated in the latter.
- 5) IEC itself does not provide any attestation of conformity. Independent certification bodies provide conformity assessment services and, in some areas, access to IEC marks of conformity. IEC is not responsible for any services carried out by independent certification bodies.
- 6) All users should ensure that they have the latest edition of this publication.
- 7) No liability shall attach to IEC or its directors, employees, servants or agents including individual experts and members of its technical committees and IEC National Committees for any personal injury, property damage or other damage of any nature whatsoever, whether direct or indirect, or for costs (including legal fees) and expenses arising out of the publication, use of, or reliance upon, this IEC Publication or any other IEC Publications.
- 8) Attention is drawn to the Normative references cited in this publication. Use of the referenced publications is indispensable for the correct application of this publication.
- 9) Attention is drawn to the possibility that some of the elements of this IEC Publication may be the subject of patent rights. IEC shall not be held responsible for identifying any or all such patent rights.

IEC 62830-8 has been prepared by IEC technical committee 47: Semiconductor devices. It is an International Standard.

The text of this International Standard is based on the following documents:

FDIS	Report on voting
47/2724/FDIS	47/2733/RVD

Full information on the voting for its approval can be found in the report on voting indicated in the above table.

The language used for the development of this International Standard is English.

This document was drafted in accordance with ISO/IEC Directives, Part 2, and developed in accordance with ISO/IEC Directives, Part 1 and ISO/IEC Directives, IEC Supplement, available at www.iec.ch/members_experts/refdocs. The main document types developed by IEC are described in greater detail at www.iec.ch/standardsdev/publications.

A list of all parts in the IEC 62830 series, published under the general title *Semiconductor devices – Semiconductor devices for energy harvesting and generation*, can be found on the IEC website.

The committee has decided that the contents of this document will remain unchanged until the stability date indicated on the IEC website under "<http://webstore.iec.ch>" in the data related to the specific document. At this date, the document will be

- reconfirmed,
- withdrawn,
- replaced by a revised edition, or
- amended.

IECNORM.COM : Click to view the full PDF of IEC 62830-8:2021

SEMICONDUCTOR DEVICES – SEMICONDUCTOR DEVICES FOR ENERGY HARVESTING AND GENERATION –

Part 8: Test and evaluation methods of flexible and stretchable supercapacitors for use in low power electronics

1 Scope

This part of IEC 62830 specifies terms, definitions, symbols, test, and evaluation methods used to determine the performance characteristics of flexible and stretchable supercapacitor for practical use in low power electronics such as energy storage devices for energy harvesting, flexible and stretchable electronics, low-power devices, IoT applications, etc. This document is applicable to all the flexible and stretchable supercapacitor for consumers and manufacturers, without any limitations of device technology and size.

2 Normative references

The following documents are referred to in the text in such a way that some or all of their content constitutes requirements of this document. For dated references, only the edition cited applies. For undated references, the latest edition of the referenced document (including any amendments) applies.

IEC 60068-1:2013, *Environmental testing – Part 1: General and guidance*

IEC 62391-1, *Fixed electric double-layer capacitors for use in electric and electronic equipment – Part 1: Generic specification*

IEC 62576, *Electric double-layer capacitors for use in hybrid electric vehicles – Test methods for electrical characteristics*

IEC 62813, *Lithium ion capacitors for use in electric and electronic equipment – Test methods for electrical characteristics*

3 Terms and definitions

For the purposes of this document, the following terms and definitions apply.

ISO and IEC maintain terminological databases for use in standardization at the following addresses:

- IEC Electropedia: available at <http://www.electropedia.org/>
- ISO Online browsing platform: available at <http://www.iso.org/obp>

3.1 General terms

3.1.1

flexible and stretchable supercapacitor

electrochemical capacitor which can be incorporated into clothing or worn on the body as accessories

Note 1 to entry: Figure A.1 in Annex A shows classification of the supercapacitor.

**3.1.2
electrical double layer capacitor
EDLC**

electrochemical capacitor in which energy storage predominantly is achieved by double-layer capacitance

Note 1 to entry: Figure A.2 shows a schematic illustration of the EDLCs.

**3.1.3
pseudocapacitor**

electrochemical capacitor in which electrical energy is stored faradaically by electron charge transfer between electrode and electrolyte

Note 1 to entry: Figure A.3 shows a schematic illustration of the pseudocapacitor.

**3.1.4
hybrid capacitor**

supercapacitor which consists of two different types of supercapacitors, such as EDLC and pseudocapacitor

Note 1 to entry: Figure A.4 shows a schematic illustration of the asymmetric hybrid supercapacitor.

Note 2 to entry: In the symmetric supercapacitor, both EDLC-like behaving material and pseudocapacitor-like behaving material are on each anode and cathode. In the asymmetric supercapacitor, EDLC-like behaving material is on cathode and pseudocapacitor-like behaving material is on anode.

**3.1.5
electrode mass**

M

mass of electroactive material for a supercapacitor

**3.1.6
cell volume**

V

volume of a supercapacitor cell

**3.1.7
electrode area**

geometric area of electroactive material for supercapacitor

**3.1.8
category temperature**

range of ambient temperatures for which the supercapacitor has been designed to operate continuously

[SOURCE: IEC 62391-1:2015, 3.8, modified – "capacitor" has been replaced by "supercapacitor" and the note has been omitted.]

**3.1.9
lower category temperature**

minimum ambient temperature for which the supercapacitor has been designed to operate continuously

[SOURCE: IEC 62391-1:2015, 3.9, modified – In the definition, "a capacitor" has been replaced by "the supercapacitor".]

3.1.10**upper category temperature**

highest ambient temperature including internal heating in which the supercapacitor is designed to operate continuously

[SOURCE: IEC 62391-1:2015, 3.10, modified – In the definition, "a capacitor" has been replaced by "the supercapacitor".]

3.1.11**rated voltage** U_r

maximum direct current (DC) voltage or peak value of pulse which may be applied continuously or repetitively to the supercapacitor at category temperature

[SOURCE: IEC 62391-1:2015, 3.12, modified – In the definition, "a capacitor" has been replaced by "the supercapacitor" and "at any temperature between the lower category temperature and rated temperature" has been replaced by "at category temperature"]

3.1.12**charging**

storage of energy in a supercapacitor

[SOURCE: IEC 60050-436:1990, 436-01-08, modified – "of a capacitor" has been removed from the term and "capacitor" has been replaced by "supercapacitor" in the definition.]

3.1.13**charging current** I_{ch}

current which flows during the charging of a supercapacitor

3.1.14**charging time** Δt_{ch}

time needed for accumulating above 90 % of the total charges to the supercapacitor

3.1.15**discharging**

release of all or part of the energy stored in a supercapacitor

[SOURCE: IEC 60050-436:1990, 436-01-10, modified – The term and definition have been adapted to supercapacitor.]

3.1.16**discharging current** I_{disch}

current which flows during the discharging of a supercapacitor

[SOURCE: IEC 60050-436:1990, 436-01-11, modified – The term and definition have been adapted to supercapacitor and a letter symbol for discharging current has been added.]

3.1.17**discharging time** Δt_{disch}

time needed for dissolving above 90 % of the total charges in the supercapacitor

3.1.18 energy efficiency

ratio of the electric energy provided from a supercapacitor during discharge to the electric energy supplied to the battery during the preceding charge

[SOURCE: IEC 60050-482:2004, 482-05-53, modified – The definition has been adapted to supercapacitor.]

3.1.19 voltage drop

U_{drop}

instantaneous change of voltage when the operation condition of a supercapacitor changes from the charging to discharging process

3.1.20 strain

change of the relative positions of parts of a supercapacitor, excluding a displacement of the body as a whole under stretching status

$$\sigma = \frac{l - l_0}{l_0} \times 100 \% \quad (1)$$

where

σ is the strain;

l is the stretched length of supercapacitor after elongation;

l_0 is the original length of supercapacitor before elongation.

[SOURCE: IEC 60050-113:2011, 113-03-57, modified – The definition has been adapted to supercapacitor, and Equation (1) added.]

3.1.21 radius of curvature bending radius

r

point of a curve, radius of the osculating circle under bending status

Note 1 to entry: The osculating circle is the circle tangent to a curve at a point that approaches at best the curve in the vicinity of the point. Figure 1 shows a schematic of curvature radius.

Note 2 to entry: The other methods to bend the supercapacitor are indicated in Annex C.

[SOURCE: IEC 60050-113:2011, 113-01-30, modified – The admitted term, letter symbol and Note 2 to entry have been added.]

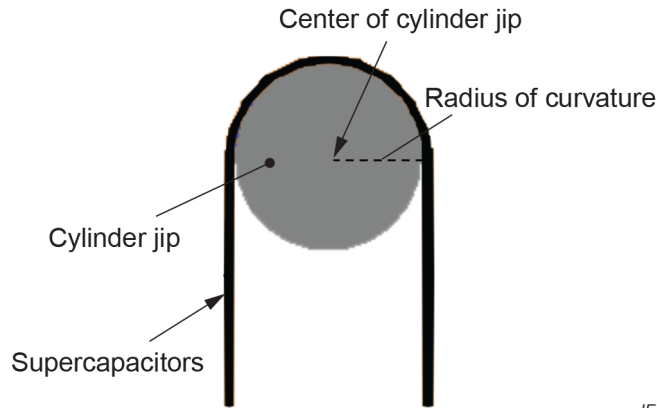

Figure 1 – Schematic of curvature radius

3.2 Characteristic parameters

3.2.1

nominal capacitance

C_N

calculated capacitance value from galvanostatic charging/discharging curve

3.2.2

specific capacitance

capacitance per unit mass/area/volume of the supercapacitor, F/g, F/cm², F/cm³

3.2.3

equivalent series resistance

internal resistance

ESR

resistance component in an equivalent series circuit of capacitance and resistance of the supercapacitor

Note 1 to entry: The internal resistance is given in ohms (Ω).

[SOURCE: IEC 62391-1:2015, 3.20, modified – The terms "equivalent series resistance" and "ESR" have been added and in the definition, "a capacitor" has been replaced by "the supercapacitor".]

3.2.4

energy density

ϵ

amount of energy that can be stored per area/mass/volume of the supercapacitor, Wh/cm², Wh/kg, Wh/cm³

3.2.5

maximum power density

P_{max}

speed at which energy can be delivered per area/mass/volume of the supercapacitor to/absorbed from the load, W/cm², W/kg, W/cm³

3.2.6

life cycle

certain number of repeated charging and discharging processes resulting in 90 % of capacitance retention

3.2.7

critical strain

strain at which the capacitance starts to decrease a predefined limit, and/or fracture of the supercapacitor caused by delamination or initiation of the cracks occurs

Note 1 to entry: It is the minimum strain that the supercapacitor can tolerate.

Note 2 to entry: Manufacturer should indicate predefined limit of strain.

[SOURCE: IEC 62951-1:2017, 3.1.2, modified – In the definition, "bending radius", "electrical resistance", "exceed", and "film" have been replaced by "strain", "capacitance", "decrease", and "supercapacitor", respectively. In addition, Note 2 to entry has been added.]

3.2.8

critical radius of curvature

bending radius at which the capacitance starts to decrease a predefined limit, and/or fracture of the supercapacitor caused by delamination or initiation of the cracks occurs

Note 1 to entry: It is the minimum radius of curvature that the supercapacitor can tolerate.

Note 2 to entry: Manufacturer should indicate predefined limit of radius of curvature.

[SOURCE: IEC 62951-1:2017, 3.1.2, modified – In the definition, "electrical resistance", "exceed", and "film" have been replaced by "capacitance", "decrease", and "supercapacitor", respectively. Note 2 to entry has been added.]

4 Essential ratings and characteristic parameters

4.1 Identification and type

The wearable electrochemical-glucose sensors shall be clearly and durably marked in the order given below:

- a) year and week (or month) of manufacture;
- b) manufacturer name or trade mark;
- c) terminal identification (optional);
- d) serial number;
- e) factory identification code (optional).

4.2 Limiting values and operating conditions

The manufacturer shall clearly announce the operating conditions and its limitations for the use of the wearable glucose sensor. Table 1 shows a list of specification for operating conditions and its limitation.

Table 1 – Table of specification parameters for flexible and stretchable supercapacitor

Parameter	Symbol	Min.	Max.	Unit	Measuring condition
<p>NOTE The following information is given in the respective columns of the table:</p> <p>Parameter: name of characteristic parameters;</p> <p>Symbol: symbol of parameters;</p> <p>Min.: minimum value of parameters;</p> <p>Max.: maximum value of parameters;</p> <p>Unit: unit of parameters;</p> <p>Measuring condition: specified condition for evaluation.</p>					

4.3 Additional information

Some additional information should be given such as operating conditions (e.g. operating temperature, storage temperature, input voltage, equivalent circuit, and power consumption, etc.), handling precautions, physical information (e.g. outline dimension, terminals, etc.), accessories, installation guide, package information, PCB interface and mounting information, and any other relevant information.

5 Test method

5.1 General

5.1.1 General

Basically, general test procedures for flexible and stretchable supercapacitor are performed as shown in Figure 2. After the supercapacitor is being mounted on a test fixture, the sample is under flat status/bending status/stretching status according to the different force such as compressive and tensile stress applied by the test machine. Simultaneously, its electrical characteristics are measured by using voltage, current and LCR meters. The readings of output voltage or current on the display of the meters are carefully taken under the bending or stretching motion. The mechanical properties are measured by using stress-applying test machines.

Flexible and stretchable supercapacitor can be characterized as shown in Figure 2. The supercapacitor is mounted onto a stress-applying test machine with flat status/bending status/stretching status according to different forces applied by the machine. Simultaneously, its electrical characteristics are measured by using current and voltage meters or equivalent equipment. If the measurements are satisfactory, reliability test for temperature range with thermal cycling and mechanical failure with various bending and stretching motions, is performed for commercially use.

NOTE The classification of flexible and stretchable supercapacitor is indicated in Annex A.

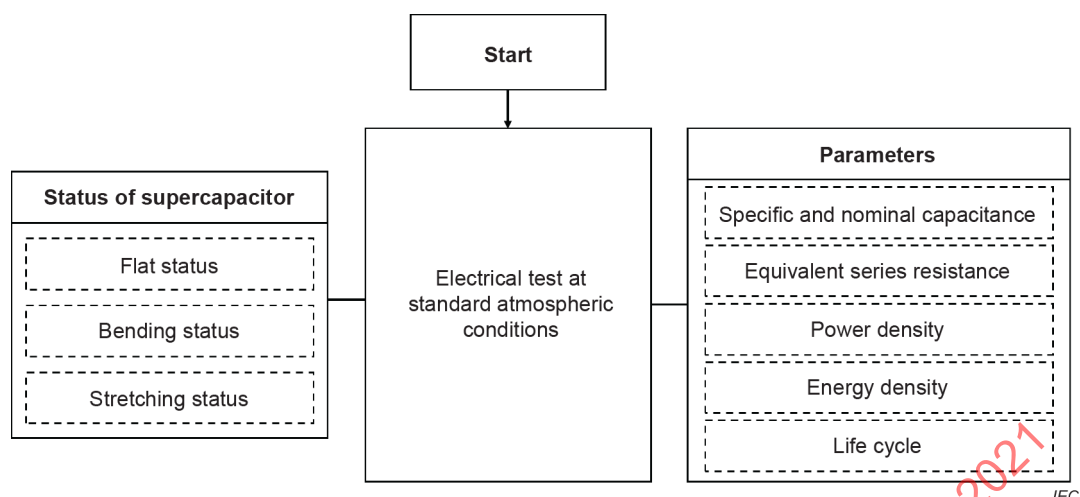
**Key**

Procedure	Reference entry and subclause	Procedure	Reference subclause
Start			
Electrical test		Reliability test	
Nominal capacitance	3.2.1 and 5.2.3.1	Bending motion	5.3
Specific capacitance	3.2.2 and 5.2.3.2	Stretching motion	5.4
Equivalent series circuit	3.2.3 and 5.2.3.3		
Energy density	3.2.4 and 5.2.3.4		
Power density	3.2.5 and 5.2.3.5		
Life cycle	3.2.6 and 5.2.3.6		

Figure 2 – Measurement procedure of flexible and stretchable supercapacitor

5.1.2 Standard atmospheric conditions for test

Unless otherwise specified, all tests shall be made under standard atmospheric conditions as given in IEC 60068-1:2013, 4.3:

- temperature : 15 °C to 35 °C;
- relative humidity : 25 % to 75 %;
- air pressure : 86 kPa to 106 kPa.

5.1.3 Standard atmospheric conditions for measurement

Unless otherwise specified, all measurement shall be made under standard atmospheric conditions as given in IEC 60068-1:2013, 4.2 with the following details:

- temperature : 25 °C ± 2 °C;
- relative humidity : 45 % to 55 %;
- air pressure : 86 kPa to 106 kPa.

5.2 Flat status

5.2.1 Measurement circuit

Flexible and stretchable supercapacitors can be measured by using constant current or constant voltage charging and discharging methods. The circuit shown in Figure 3 can be used for the measurement of characteristic parameters.

Measurement circuit of the supercapacitor shall apply the related standards, IEC 62813 and IEC 62391-1. The measurement circuit shall be able to measure constant current charge/discharge, constant voltage charge/discharge of the flexible supercapacitor, and continuous measure current and voltage through the supercapacitor terminals. For accurate measuring and characterizing results, ultra-high-impedance meters should be used.

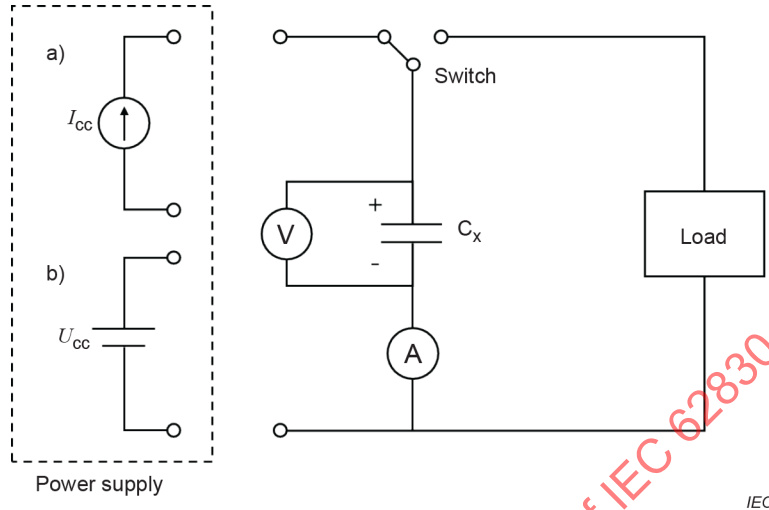

Key:

Components of the measurement circuit of supercapacitor

C_x	Supercapacitor under test	Power supply	Constant current I_{cc} or Constant voltage U_{cv}
A	DC current meter	V	DC voltage meter
R	Load resistor	S	Changeover switch

Figure 3 – Measurement circuit of flexible and stretchable supercapacitor

5.2.2 Measurement procedure

The measurement of the supercapacitor by using constant current method shall apply the related standard, IEC 62576. It is assumed that flexible and stretchable supercapacitor to be tested behaves as ideal electric double-layer capacitor with constant C_S and equivalent series resistance ESR values. The measurement equipment shall be set-up in the following manner.

- Set the constant charging current I_{ch} . At this current, the flexible and stretchable supercapacitor shall be able to charge with 90 % charging efficiency based on their equivalent series resistance ESR , the charging current value is calculated by $I_{ch} = U_r/38ESR$
- Set the maximum voltage as the rated voltage U_r for constant current charging process.
- Disconnect the charging circuit, connect to the discharging circuit using the changeover switch S. Set the constant discharge current value. This value shall allow for a 90 % discharging efficiency based on the supercapacitor's equivalent series resistance ESR , and is calculated by $I_{disch} = U_r/40ESR$.
- After the measurement according to the above setup, the voltage-time characteristics between the two terminals of the tested flexible and stretchable supercapacitor as shown in Figure 4 shall be obtained.

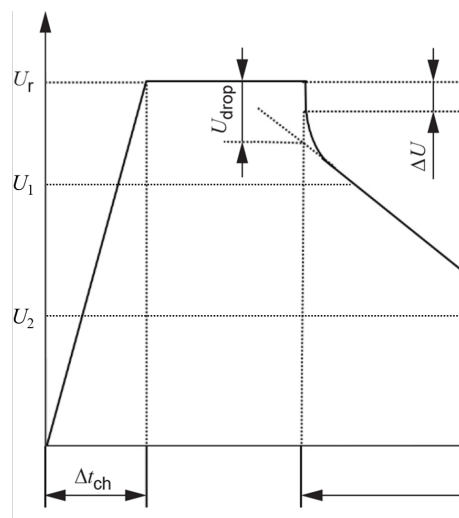
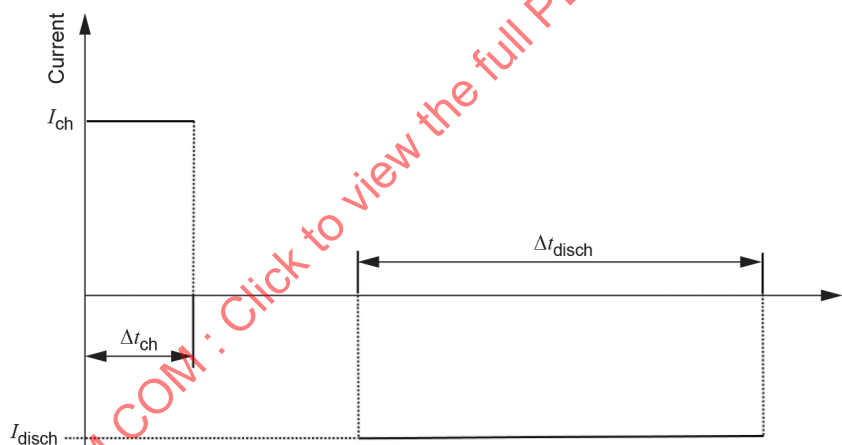

Figure 4 – Schematic illustration of the voltage-time (V-t) curve of the tested flexible and stretchable supercapacitor

- e) The current-time characteristics between the two terminals of the tested flexible and stretchable supercapacitor as shown in Figure 5 shall be obtained.



IEC

Figure 5 – Schematic illustration of current-time (I-t) curve of the tested flexible and stretchable supercapacitor

- f) the current-voltage characteristics between the two terminals of the flexible and stretchable supercapacitor as shown in Figure 6 shall be obtained.

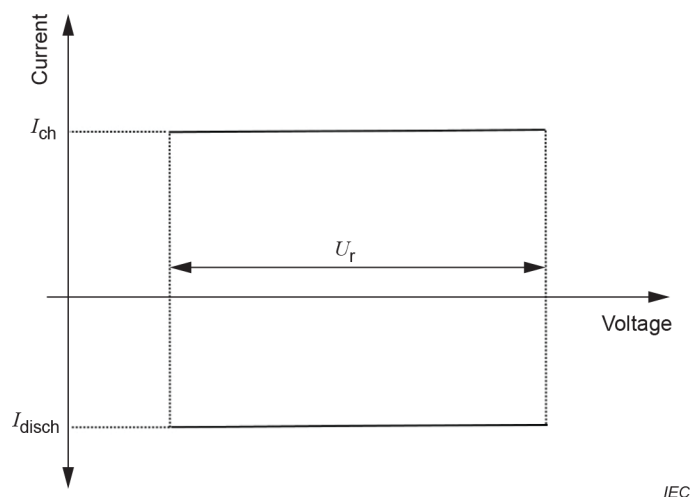

Figure 6 – Schematic illustration of the voltage-current (V-I) curve of the tested flexible and stretchable supercapacitor

5.2.3 Essential parameters calculation

5.2.3.1 Nominal capacitance

The nominal capacitance C_N shall be calculated from charging-discharging curve in Figure 7, using Equation (2) based on the measured voltage time characteristics between flexible and stretchable supercapacitor terminals.

$$C_N = \frac{I_{\text{disch}} \cdot \Delta t_{\text{disch}}}{\Delta U} \quad (2)$$

ΔU is the change in potential, V, and is chosen as follows:

$$\Delta U = U_1 - U_2 \quad (3)$$

where,

U_1 is the measuring start voltage (V), which is defined as $0,8 \times U_r$;

U_2 is the measuring end voltage (V), which is defined as $0,4 \times U_r$.

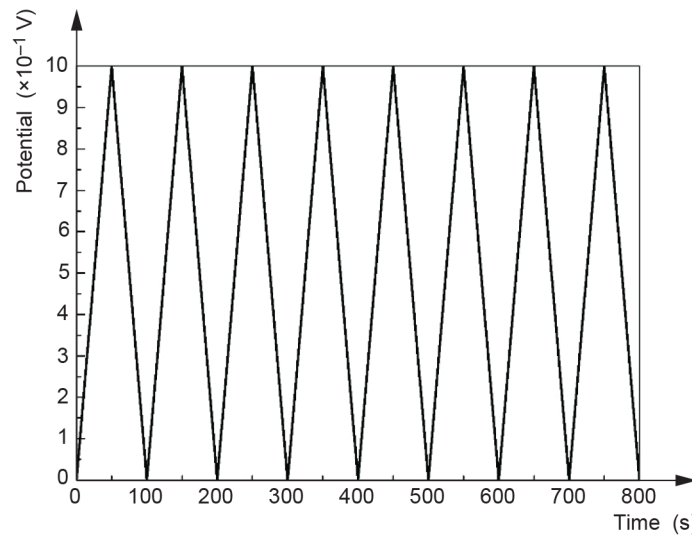

Figure 7 – Voltage-time curves during ten continuous charging-discharging processes of flexible and stretchable supercapacitor

5.2.3.2 Specific capacitance

The specific capacitance C_s shall be divided by unit mass/area/volume of the supercapacitor.

5.2.3.3 Equivalent series resistance

The determination of the equivalent series resistance of the supercapacitor is complicated by the fact that the voltage decreases due to the equivalent series resistance and loss of charge. The equivalent series resistance can be represented as an internal resistance. The ESR value, when discharging the supercapacitor with the constant current I_{disch} , can be calculated from the value of voltage drop U_{drop} when the current direction changes from the discharging process to charging process or vice versa.

$$ESR = \frac{U_{drop}}{\Delta I} \quad (4)$$

where,

ΔI is the difference between current values before (I_1) and after (I_2) the current direction changes $\Delta I = |I_1 - I_2|$.

5.2.3.4 Energy density

Energy density in unit of Wh/Kg, Wh/cm², and Wh/cm³ is the energy that a supercapacitor can store at charging up to the rated voltage. It can be calculated using the following Equation (5).

$$E_{max} = \frac{C_s U_r}{2 \times 3600} \quad (5)$$

5.2.3.5 Maximum power density

The maximum power density P_{max} is calculated by “matched impedance power density method” using the equivalent series resistance value and the following Equation (6).

$$P_{max} = \frac{U_r^2}{4 \times ESR} \tag{6}$$

5.2.3.6 Life cycle

Figure 7 shows a typical repeated charging/discharging curve of measured potential versus time of flexible and stretchable supercapacitor. The nominal capacitance shall be calculated on each cycle in this curve. Figure 8 shows the capacitance retention according to cycling numbers.

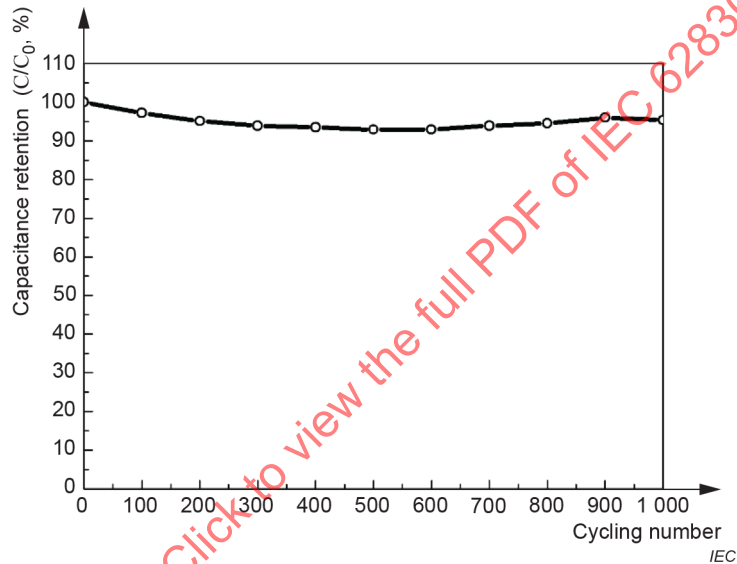
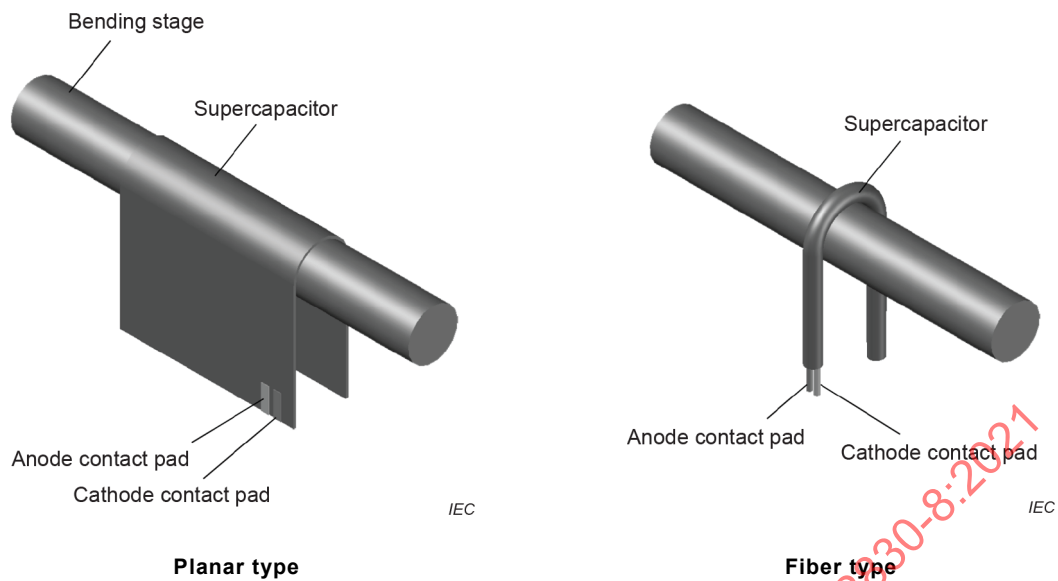

Figure 8 – Calculated capacitance retention after certain number of repeated charging-discharging processes of flexible and stretchable supercapacitor

5.3 Bending status

5.3.1 General

The objective of this test is to evaluate the performance reliability of the flexible and stretchable supercapacitor under bending motion. First, the measurement of the flexible and stretchable supercapacitor is performed under various radius of curvature values, r , as shown in Figure 9. Second, cycling test is performed by repeating the bending and relaxing processes and the performance characteristics is monitored at the same time. The supercapacitor is half rounded surrounding bending stages with various radius of curvature as half-circle to test under bending condition.

**Key****Components of setup to bend supercapacitor with specific radius of curvature**

Bending stage	Solid cylinder to round and bend supercapacitor with specific radius of curvature
Cathode contact pad	Contact pad to be connected to cathode electrode of supercapacitor
Anode contact pad	Contact pad to be connected to anode electrode of supercapacitor

Figure 9 – Bending method of flexible and stretchable supercapacitor using bending stage

5.3.2 Test procedure

Figure 10 shows a test setup to evaluate the performance reliability of the flexible and stretchable supercapacitor under bending status. To measure the energy storage performance under the bending status, the supercapacitor shall be half rounded and fixed on a bending stage with specific radius of curvature, and the anode and cathode of the flexible and stretchable supercapacitor are connected to test equipment as shown in Figure 10. The test equipment shall be capable of constant current charging, constant voltage charging, constant discharging and continuous measurement of the current and the voltage between the two terminals of the supercapacitor in time series as shown in Figure 10. When the supercapacitor is loaded on bending stage, the output of voltage or current between the two terminals in time series is measured.

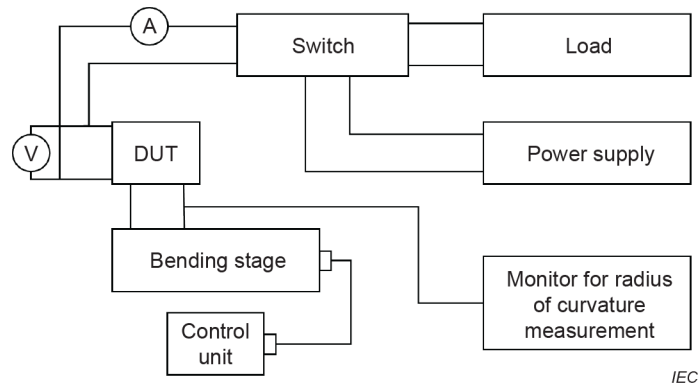

Key

Component and meters to monitor		Equipment and supplies	
DUT: device under test	A piece of flexible and stretchable supercapacitor	Power supply	To charge the supercapacitor
Voltage meter (V)	To detect a voltage of the supercapacitor	Control unit	To supply and adjust an electrical signal to the radius of curvature motor
Ampere meter (A)	To detect a current through the supercapacitor	Bending stage	To supply a specified values of radius of curvature to a piece of DUT
Load	To discharge the supercapacitor	Monitor for radius of curvature measurement	To detect an bending status
Switch	Change between the charging and discharging circuits		

Figure 10 – Test setup for the performance reliability of flexible and stretchable supercapacitor under bending condition

The following test procedure is performed:

- a) Half round and mount the flexible and stretchable supercapacitor on bending stage with specific radius of curvature.
- b) Fix and connect the two terminals of the supercapacitor to the test equipment.
- c) Measure and calculate the specific capacitance of the flexible and stretchable supercapacitor at various bending radius of curvature values, r , as shown in Figure 11 and Figure 12.

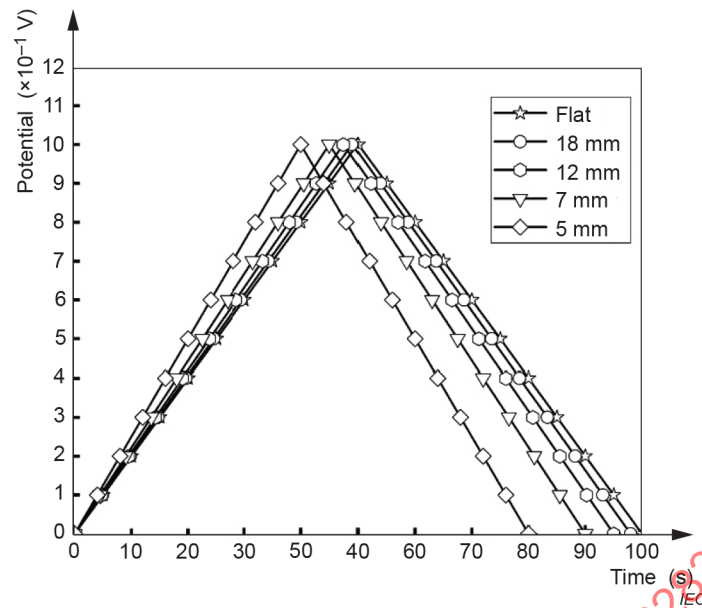

Figure 11 – Comparison of charging-discharging curves with different curvature values of a flexible and stretchable supercapacitor

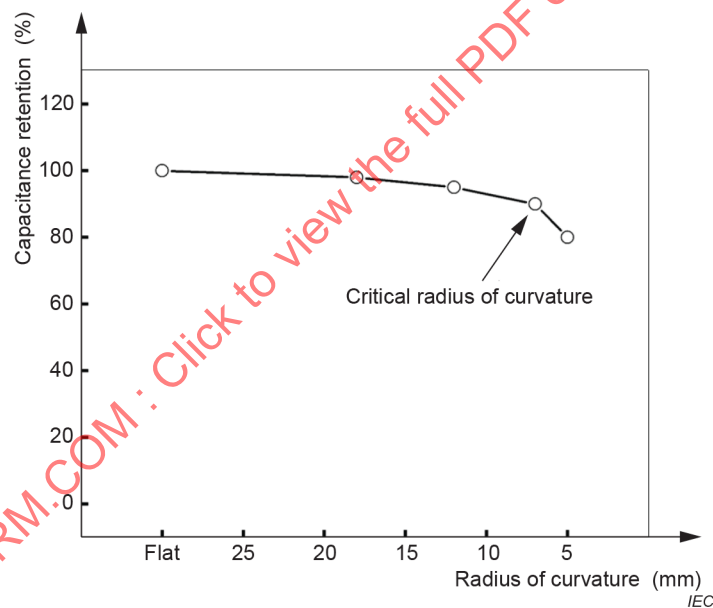

Figure 12 – Capacitance retention of flexible and stretchable supercapacitor under bending status

- d) Obtain the maximum radius of curvature where the flexible and stretchable supercapacitor can endure over critical radius of curvature
- e) Repeat under the maximum radius or curvature obtained in d), and measure and calculate the capacitance retention after each cycle, according to the following Equation (7), as shown in Figure 13.

$$\eta = \frac{C_n}{C_1} \times 100\% \tag{7}$$

where,

- η is the capacitance retention;
- C_n is the final capacitance after repeating n times;
- C_1 is the initial capacitance.

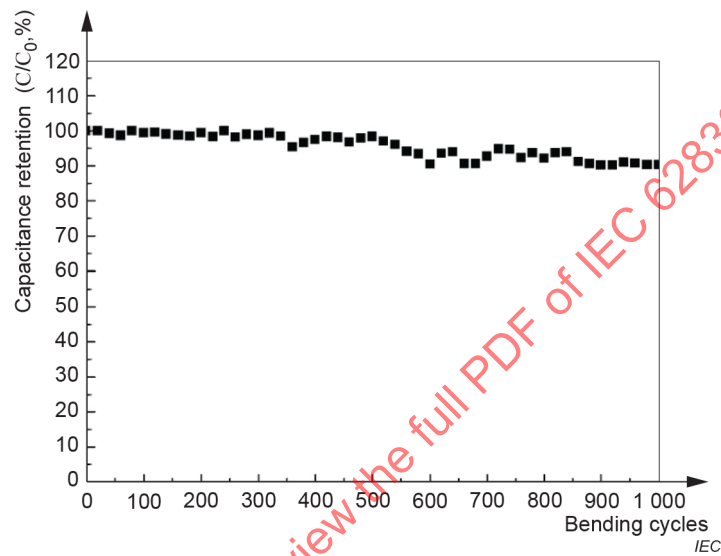
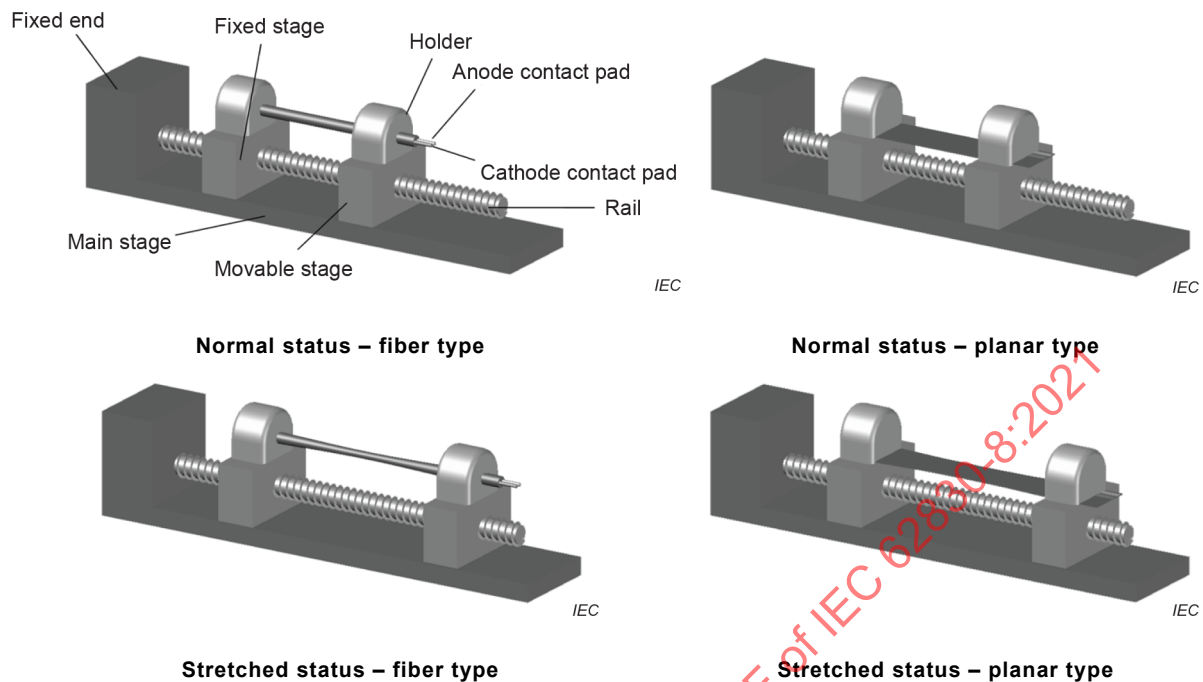

Figure 13 – Performance reliability of flexible and stretchable supercapacitor under bending status

5.4 Stretching status

5.4.1 General

The objective of this test is to evaluate the performance reliability of the flexible and stretchable supercapacitor under stretching motion. The stretching range should be specified from the applications. The test shall be performed according to cycling test of induced stretching motion by placing the supercapacitor on the stretching motor, as shown in Figure 14. The performance characteristics are monitored by current and voltage meters. The stretchable supercapacitor is loaded on a fixed and movable stage to test under stretching motion.

**Key****Component and meters to monitor**

Main stage	Part to support total system, on which fixed and movable stage are mounted	Rail	Path that movable stage moves on the stage
Fixed end	Part of main stage to fix the rail	Movable stage	Moving stage according to rail with a side of supercapacitor
Fixed stage	Fixed staged on the main stage	Holder	Holding the supercapacitor on fixed and movable stages
Anode contact pad	Contact pad to be connected to anode electrode of supercapacitor	Cathode contact pad	Contact pad to be connected to cathode electrode of supercapacitor

Figure 14 – Stretching method of flexible and stretchable supercapacitor using stretching stage

5.4.2 Test procedure

Figure 15 shows a test setup of the performance reliability of a flexible and stretchable supercapacitor under stretching condition. The device should be mounted on a sample holder with the two electrodes of the supercapacitor connected to the stretching stage and electrochemical workstation (test equipment) as shown in Figure 15. The test equipment shall be capable of constant current charging, constant voltage charging, constant discharging and continuous measurement of the current and the voltage between the two supercapacitor terminals in time series. When the fixed strain is applied to the device, an output of voltage or current between the two supercapacitor terminals in time series is measured. When continuous bending/stretching motion with specified acceleration (the various strain within certain range) is applied to the device, a continuous output of current/voltage between the two supercapacitor terminals in time series is measured.

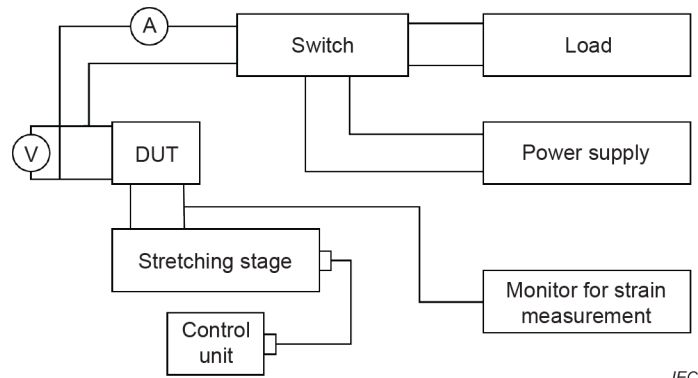

IEC

Key

Component and meters to monitor		Equipment and supplies	
DUT: device under test	A piece of flexible and stretchable supercapacitor	Power supply	To charge the supercapacitor
Voltage meter (V)	To detect a voltage of the supercapacitor	Control unit	To supply a specified frequency of electrical signal to the linear motor
Ampere meter (A)	To detect a current through the supercapacitor	Stretching stage	To supply a specified level and frequency of stretching motion to a piece of DUT by using motor
Load	To discharge the supercapacitor	Monitor for strain measurement	To detect a stretch status
Switch	Change between the charging and discharging processes		

Figure 15 – Test setup for the performance reliability of flexible and stretchable supercapacitor under stretching condition

The following test procedure is performed (for fixed strain):

- a) Mount the sample flexible and stretchable supercapacitor on test stage under stretching motion.
- b) Fix and connect the two terminals of the supercapacitor to the test equipment.
- c) A specified strain is applied to the flexible and stretchable supercapacitor through the stretching motor.
- d) Measure and calculate the specific capacitance of the flexible and stretchable supercapacitor at various strain, as shown in Figure 16 and Figure 17.

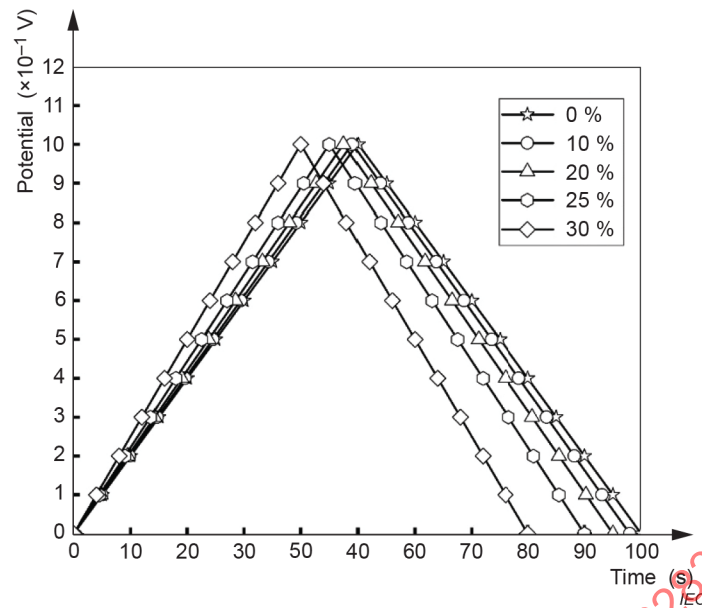

Figure 16 – Comparison of charging-discharging processes of flexible and stretchable supercapacitor under various strain status

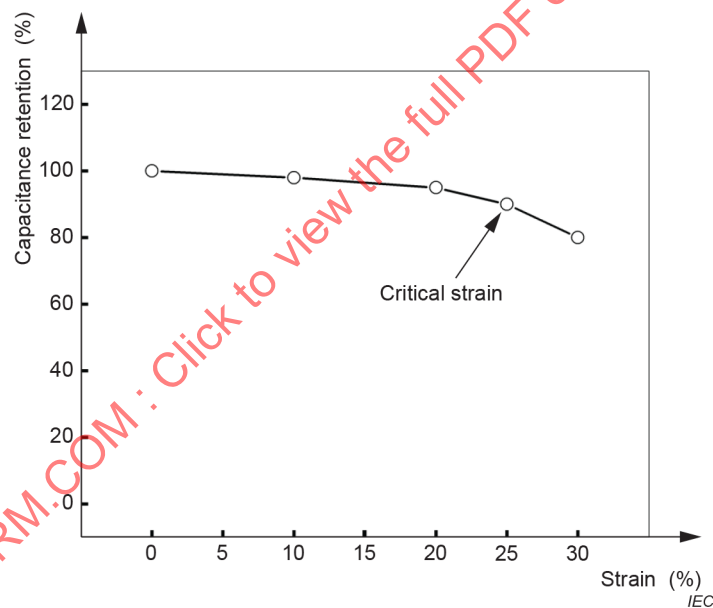

Figure 17 – Capacitance retention of flexible and stretchable supercapacitor under stretching status

- e) Obtain the maximum strain where the flexible and stretchable supercapacitor can endure over critical strain.
- f) Repeat under the maximum strain obtained in e), and measure and calculate the capacitance retention after each cycle, according to the following Equation (7), as shown in Figure 18.

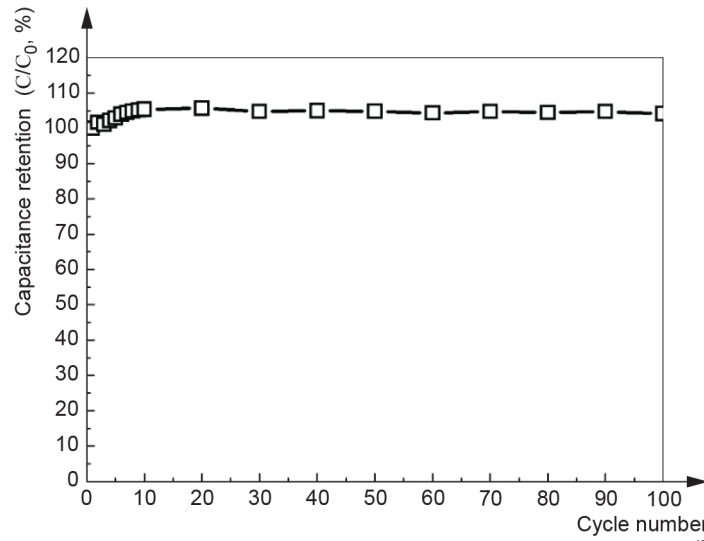

Figure 18 – Reliability of flexible and stretchable supercapacitor under stretching status

6 Test reports

The test report shall include at least the following information:

a) mandatory:

- 1) reference to this document;
- 2) shape, weight and dimensions of the tested supercapacitor;
- 3) environmental condition for test:
 - external load;
 - atmospheric conditions (temperature, humidity, pressure) for test;
 - charging/discharging current;
 - charging/discharging time;
 - test range of strain;
 - test range of bending radius;

4) characteristics:

- nominal capacitance;
- measurement accuracy;
- energy density;
- maximum power density;
- life cycle;
- critical strain (or maximum strain);
- critical radius of curvature (or maximum radius of curvature);
- rated temperature;

b) optional:

- 1) purpose of testing;
- 2) structure of tested device;
- 3) principle of charging/discharging and energy storage;
- 4) characteristics;
 - voltage drop;
 - specific capacitance.

IECNORM.COM : Click to view the full PDF of IEC 62830-8:2021

Annex A (informative)

Classification of supercapacitors and its working principles

A.1 General

This Annex A describes the classification of the supercapacitor and its working principles.

A.2 Classification

Supercapacitor is classified to electrical double layer capacitor, pseudocapacitor, and hybrid capacitors, where the hybrid capacitors are classified to asymmetric hybrid supercapacitor, symmetric hybrid supercapacitor, and battery-like hybrid supercapacitor, as shown in Figure A.1.

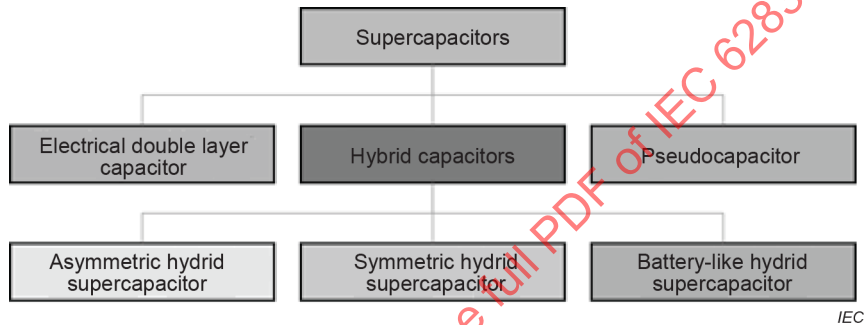

Figure A.1 – Classification of supercapacitor according to its operation principles

A.3 Working principles

A.3.1 Electrical double layer capacitor (EDLC)

When the potential is applied on the electrode, charges are stacked on interface between electrode and electrolyte, which makes electric double layer capacitor, as shown in Figure A.2.

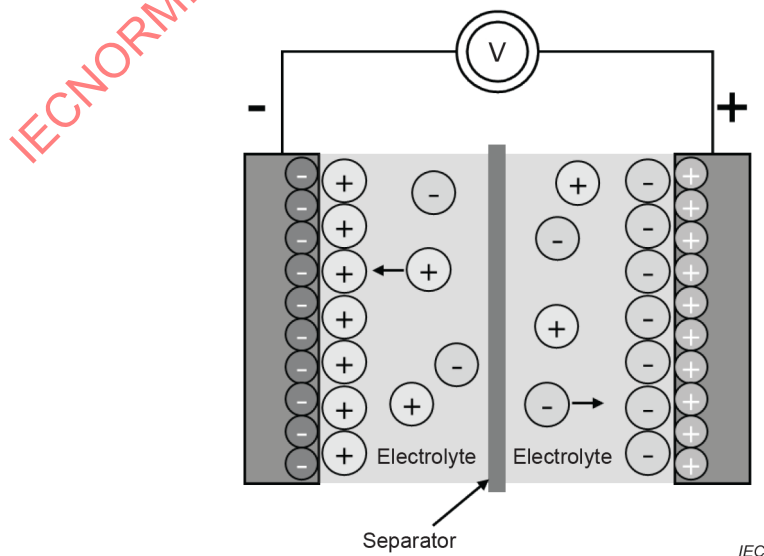

Figure A.2 – Schematic illustration of the configuration of EDLC

A.3.2 Pseudocapacitor

When the potential is applied on the electrode, redox reaction occurs on the interface between electrode and electrolyte, which makes similar effect to that of a capacitor, as shown in Figure A.3.

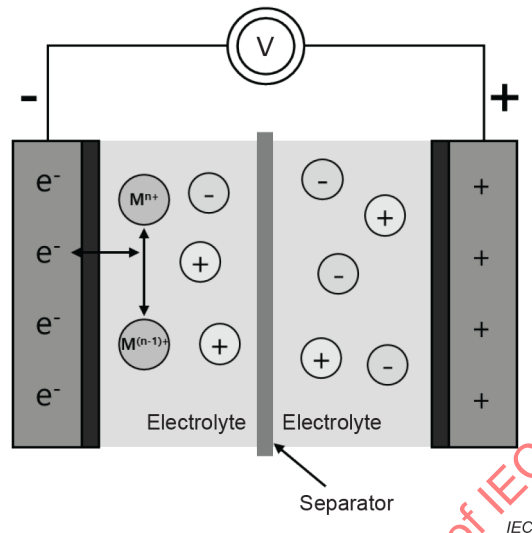

Figure A.3 – Schematic illustration of the configuration of pseudocapacitor

A.3.3 Hybrid supercapacitor

When the potential is applied on the electrode, an accumulation of charges like EDLC and redox reaction like pseudocapacitor occurs at the same time. Figure A.4 shows the working principle of asymmetric hybrid supercapacitor.

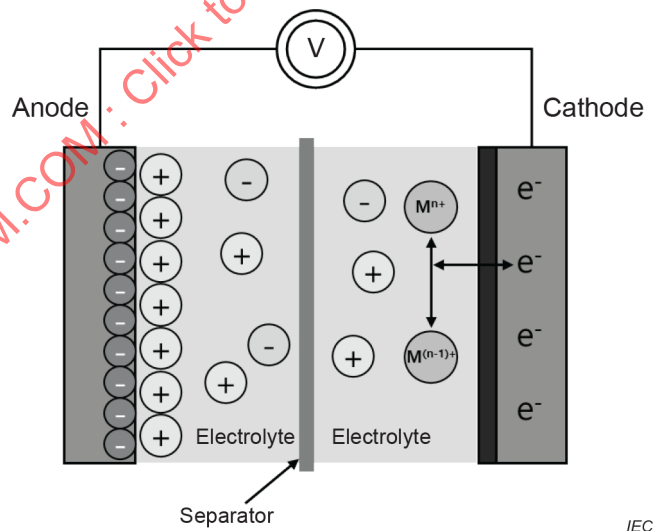

Figure A.4 – Schematic illustration of the configuration of asymmetric hybrid supercapacitor

Annex B (informative)

Endurance test (continuous application of rated voltage at low or high temperature)

B.1 General

This Annex B describes the endurance test for continuous application of rated voltage at high temperature to determine the rated voltage defined in 3.1.11.

NOTE The test method is described in IEC 62576:2018, Annex A and is modified: "capacitor" has been replaced by "supercapacitor", and the temperature range and the specified duration have been amended.

B.2 Test method

B.2.1 Test conditions

Unless otherwise given in the relevant specification, the test conditions should be as follows:

- temperature: lower category temperature or upper category temperature;
- voltage: rated voltage;
- duration: 1 000 h.

B.2.2 Test procedure

The test procedure should be as follows.

- a) Pre-conditioning
Before measurement, the supercapacitor shall be fully discharged and then incubated for 2 h to 6 h under the reference temperature, which shall be set at $25\text{ °C} \pm 2\text{ °C}$, as specified in 4.2 in IEC 60068-1:2013.
- b) Initial measurements
The capacitance and the internal resistance shall be measured and according to the procedure described in 5.2, 5.3, and 5.4.
- c) Testing
Place the supercapacitor in a chamber at lower category temperature or upper category temperature and apply the rated voltage for specified duration. Charging it up to the specified rated voltage shall be carried out by applying a current that provides 95 % charging efficiency based on the internal resistance of the supercapacitor.
- d) Post-treatment (recovery)
After the test is complete, remove the supercapacitor from the test chamber, discharge completely and soak them in the reference temperature, set at $25\text{ °C} \pm 2\text{ °C}$, as specified in 5.2 in IEC 60068-1:2013 for specified duration.
- e) Final measurement
Apart from visual inspection, the capacitance and the internal resistance of the supercapacitor shall be measured in accordance with the procedure of 5.2, 5.3, and 5.4, and the rates of change from their initially measured values shall be obtained.

B.2.3 Recommendations

Unless otherwise agreed between manufacturer and customer, the capacitance change ΔC and equivalent series resistance change ΔR should meet the following values.