**Rolling bearings — Radial needle roller
and cage assemblies — Boundary
dimensions and tolerances**

*Roulements — Cages à aiguilles radiales — Dimensions
d'encombrement et tolérances*

STANDARDSISO.COM : Click to view the full PDF of ISO 3030:2011



STANDARDSISO.COM : Click to view the full PDF of ISO 3030:2011



COPYRIGHT PROTECTED DOCUMENT

© ISO 2011

All rights reserved. Unless otherwise specified, no part of this publication may be reproduced or utilized in any form or by any means, electronic or mechanical, including photocopying and microfilm, without permission in writing from either ISO at the address below or ISO's member body in the country of the requester.

ISO copyright office
Case postale 56 • CH-1211 Geneva 20
Tel. + 41 22 749 01 11
Fax + 41 22 749 09 47
E-mail copyright@iso.org
Web www.iso.org

Published in Switzerland

Foreword

ISO (the International Organization for Standardization) is a worldwide federation of national standards bodies (ISO member bodies). The work of preparing International Standards is normally carried out through ISO technical committees. Each member body interested in a subject for which a technical committee has been established has the right to be represented on that committee. International organizations, governmental and non-governmental, in liaison with ISO, also take part in the work. ISO collaborates closely with the International Electrotechnical Commission (IEC) on all matters of electrotechnical standardization.

International Standards are drafted in accordance with the rules given in the ISO/IEC Directives, Part 2.

The main task of technical committees is to prepare International Standards. Draft International Standards adopted by the technical committees are circulated to the member bodies for voting. Publication as an International Standard requires approval by at least 75 % of the member bodies casting a vote.

Attention is drawn to the possibility that some of the elements of this document may be the subject of patent rights. ISO shall not be held responsible for identifying any or all such patent rights.

ISO 3030 was prepared by Technical Committee ISO/TC 4, *Rolling bearings*, Subcommittee SC 5, *Needle roller bearings*.

This third edition cancels and replaces the second edition (ISO 3030:1996), which has been technically revised.

STANDARDSISO.COM : Click to view the full PDF of ISO 3030:2011

[STANDARDSISO.COM](https://standardsiso.com) : Click to view the full PDF of ISO 3030:2017

Rolling bearings — Radial needle roller and cage assemblies — Boundary dimensions and tolerances

1 Scope

This International Standard specifies the boundary dimensions for radial needle roller and cage assemblies.

In addition, it gives the tolerances for the cage width and method of functional gauging of smallest single bore diameter of needle roller complement.

Informative values for the tolerances of shaft raceway, housing raceway and raceway widths are given in Annex A.

2 Normative references

The following referenced documents are indispensable for the application of this document. For dated references, only the edition cited applies. For undated references, the latest edition of the referenced document (including any amendments) applies.

ISO 1132-1, *Rolling bearings — Tolerances — Part 1: Terms and definitions*

ISO 1132-2:2001, *Rolling bearings — Tolerances — Part 2: Measuring and gauging principles and methods*

ISO 3096, *Rolling bearings — Needle rollers — Dimensions and tolerances*

ISO 5593, *Rolling bearings — Vocabulary*

ISO 15241, *Rolling bearings — Symbols for quantities*

3 Terms and definitions

For the purposes of this document, the terms and definitions given in ISO 1132-1 and ISO 5593 apply.

4 Symbols

For the purposes of this document, the symbols given in ISO 15241 and the following apply.

The symbols (except those for tolerances) shown in Figure 1 and the values given in Tables 1 to 4 denote nominal dimensions unless specified otherwise.

B_c cage width

E_w outside diameter of needle roller complement

F_w bore diameter of needle roller complement

$\Delta_{B_{CS}}$ deviation of a single cage width

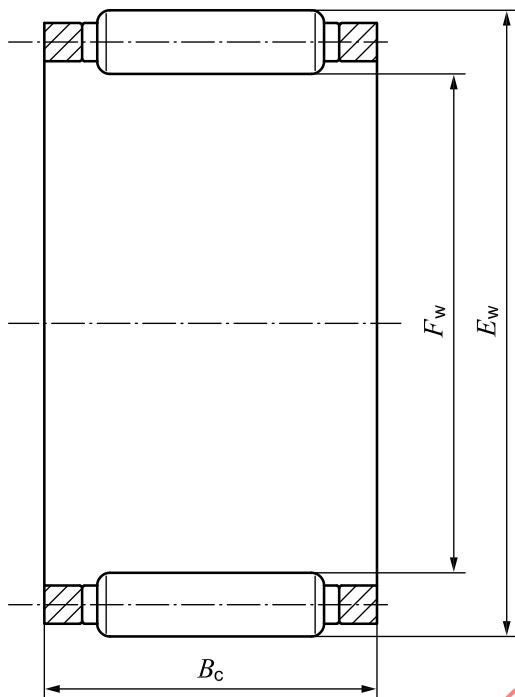

NOTE Radial needle roller and cage assemblies can also be with two rows of needle roller or split-type.

Figure 1 — Radial needle roller and cage assembly

STANDARDSISO.COM : Click to view the full PDF of ISO 3030:2011

5 Boundary dimensions

The general plan is given in Tables 1 and 2.

Table 1 — Diameter series 1C and 2C

Dimensions in millimetres

F_w	Diameter series 1C								Diameter series 2C							
	E_w	B_c							E_w	B_c						
		Dimension series								Dimension series						
		11C	21C	31C	41C	51C	61C	71C		12C	22C	32C	42C	52C	62C	72C
4	7	6	8	10	—	—	—	—	—	—	—	—	—	—	—	—
5	8	6	8	10	13	—	—	—	9	8	10	13	—	—	—	—
6	9	6	8	10	13	15	—	—	10	8	10	13	15	—	—	—
7	10	6	8	10	13	15	17	—	11	8	10	13	15	17	—	—
8	11	6	8	10	13	15	17	—	12	8	10	13	15	17	20	—
9	12	6	8	10	13	15	17	—	13	8	10	13	15	17	20	—
10	13	6	8	10	13	15	17	—	14	8	10	13	15	17	20	—
12	15	6	8	10	13	15	17	—	16	8	10	13	15	17	20	—
14	18	8	10	13	15	17	20	23	19	10	13	15	17	20	23	27
15	19	8	10	13	15	17	20	23	20	10	13	15	17	20	23	27
16	20	8	10	13	15	17	20	23	21	10	13	15	17	20	23	27
17	21	8	10	13	15	17	20	23	22	10	13	15	17	20	23	27
18	22	8	10	13	15	17	20	23	23	10	13	15	17	20	23	27
20	24	8	10	13	15	17	20	23	25	10	13	15	17	20	23	27
22	26	8	10	13	15	17	20	23	27	10	13	15	17	20	23	27
25	29	8	10	13	15	17	20	23	30	10	13	15	17	20	23	27
28	33	10	13	15	17	20	23	27	34	12	15	17	20	25	30	35
30	35	10	13	15	17	20	23	27	36	12	15	17	20	25	30	35
32	37	10	13	15	17	20	23	27	38	12	15	17	20	25	30	35
35	40	10	13	15	17	20	23	27	41	12	15	17	20	25	30	35
38	43	10	13	15	17	20	23	27	44	12	15	17	20	25	30	35
40	45	10	13	15	17	20	23	27	46	12	15	17	20	25	30	35
42	47	10	13	15	17	20	23	27	48	12	15	17	20	25	30	35
45	50	10	13	15	17	20	23	27	51	12	15	17	20	25	30	35
50	55	10	13	15	17	20	23	27	56	12	15	17	20	25	30	35
55	61	12	15	17	20	25	30	35	62	16	20	25	30	35	40	—
60	66	12	15	17	20	25	30	35	67	16	20	25	30	35	40	—
65	71	12	15	17	20	25	30	35	72	16	20	25	30	35	40	—
70	76	12	15	17	20	25	30	35	77	16	20	25	30	35	40	—
75	81	12	15	17	20	25	30	35	82	16	20	25	30	35	40	—
80	86	12	15	17	20	25	30	35	87	16	20	25	30	35	40	—
85	92	16	20	25	30	35	40	—	93	20	25	30	35	40	45	—
90	97	16	20	25	30	35	40	—	98	20	25	30	35	40	45	—
95	102	16	20	25	30	35	40	—	103	20	25	30	35	40	45	—
100	107	16	20	25	30	35	40	—	108	20	25	30	35	40	45	—

Table 2 — Diameter series 3C, 4C and 5C

Dimensions in millimetres

F_w	Diameter series 3C							Diameter series 4C							Diameter series 5C				
	E_w	B_c						E_w	B_c						E_w	B_c			
		Dimension series							Dimension series							Dimension series			
		13C	23C	33C	43C	53C	63C		14C	24C	34C	44C	54C	64C		15C	25C	35C	45C
6	11	10	13	15	—	—	—	—	—	—	—	—	—	—	—	—	—	—	—
7	12	10	13	15	17	—	—	—	—	—	—	—	—	—	—	—	—	—	—
8	13	10	13	15	17	20	—	14	12	15	17	20	—	—	—	—	—	—	—
9	14	10	13	15	17	20	—	15	12	15	17	20	—	—	—	—	—	—	—
10	15	10	13	15	17	20	—	16	12	15	17	20	—	—	17	16	20	25	—
12	17	10	13	15	17	20	23	18	12	15	17	20	—	—	19	16	20	25	—
14	20	12	15	17	20	25	30	21	16	20	25	30	35	—	22	20	25	30	—
15	21	12	15	17	20	25	30	22	16	20	25	30	35	—	23	20	25	30	—
16	22	12	15	17	20	25	30	23	16	20	25	30	35	—	24	20	25	30	35
17	23	12	15	17	20	25	30	24	16	20	25	30	35	—	25	20	25	30	35
18	24	12	15	17	20	25	30	25	16	20	25	30	35	40	26	20	25	30	35
20	26	12	15	17	20	25	30	27	16	20	25	30	35	40	28	20	25	30	35
22	28	12	15	17	20	25	30	29	16	20	25	30	35	40	30	20	25	30	35
25	31	12	15	17	20	25	30	32	16	20	25	30	35	40	33	20	25	30	35
28	35	16	20	25	30	35	40	36	20	25	30	35	40	45	38	25	30	35	40
30	37	16	20	25	30	35	40	38	20	25	30	35	40	45	40	25	30	35	40
32	39	16	20	25	30	35	40	40	20	25	30	35	40	45	42	25	30	35	40
35	42	16	20	25	30	35	40	43	20	25	30	35	40	45	45	25	30	35	40
38	45	16	20	25	30	35	40	46	20	25	30	35	40	45	48	25	30	35	40
40	47	16	20	25	30	35	40	48	20	25	30	35	40	45	50	25	30	35	40
42	49	16	20	25	30	35	40	50	20	25	30	35	40	45	52	25	30	35	40
45	52	16	20	25	30	35	40	53	20	25	30	35	40	45	55	25	30	35	40
50	57	16	20	25	30	35	40	58	20	25	30	35	40	45	60	25	30	35	40
55	63	20	25	30	35	40	45	65	25	30	35	40	45	50	70	35	40	45	50
60	68	20	25	30	35	40	45	70	25	30	35	40	45	50	75	35	40	45	50
65	73	20	25	30	35	40	45	75	25	30	35	40	45	50	80	35	40	45	50
70	78	20	25	30	35	40	45	80	25	30	35	40	45	50	85	35	40	45	50
75	83	20	25	30	35	40	45	85	25	30	35	40	45	50	90	35	40	45	50
80	88	20	25	30	35	40	45	90	25	30	35	40	45	50	95	35	40	45	50
85	95	25	30	35	40	45	50	100	35	40	45	50	60	—	105	45	50	60	70
90	100	25	30	35	40	45	50	105	35	40	45	50	60	—	110	45	50	60	70
95	105	25	30	35	40	45	50	110	35	40	45	50	60	—	115	45	50	60	70
100	110	25	30	35	40	45	50	115	35	40	45	50	60	—	120	45	50	60	70

6 Tolerances

6.1 Tolerances for the needle roller diameter

Diameter tolerances and “gauges” of needle rollers shall be in accordance with ISO 3096.

The needle roller grade should be agreed between the customer and the supplier.

6.2 Tolerance for the cage width

The tolerance for cage width, B_c , is given in Table 3.

Table 3 — Cage width tolerances

Tolerance values in millimetres

B_c	$\Delta_{B_{CS}}$	
	high	low
All widths	- 0,2	0,8

7 Functional gauging and gauge dimensions

Functional gauging of smallest single bore diameter of needle roller complement shall be carried out in accordance with ISO 1132-2:2001, 7.6.

The functional gauge dimensions are given in Table 4.

Table 4 — Functional gauge dimensions

Dimensions in millimetres

E_w		Functional gauge dimensions	
>	≤	Plug gauge diameter	Ring gauge diameter
—	6	equal to F_w	$E_w + 0,004$
6	10		$E_w + 0,005$
10	18		$E_w + 0,006$
18	30		$E_w + 0,007$
30	50		$E_w + 0,009$
50	80		$E_w + 0,010$
80	120		$E_w + 0,012$

Annex A (informative)

Tolerances for shaft raceway, housing raceway and raceway widths

A.1 General

Proper function of radial needle roller and cage assemblies depends on the features of the housing raceway, the shaft raceway, the raceway width and the axial guidance surfaces.

Table values are informative only and it is possible that they are not suitable for use in applications having certain operating conditions and features. In case of doubt, the bearing manufacturer should be consulted for specific advice.

The raceways are hardened and finish ground.

Surface hardness is minimum 670 HV.

A.2 Tolerances for shaft raceway and housing raceway

Tables A.1 and A.2 show tolerances for housing raceway and shaft raceway suggested for general use and normal operating clearance.

Table A.1 — Tolerances for housing raceway

Tolerance values in micrometres

Nominal housing raceway diameter mm		Deviation of housing raceway diameter G6		Surface roughness <i>Ra</i> max.	Roundness ^a	Variation of mean diameter ^b
					IT3 max.	IT3 max.
>	≤	high	low			
6	10	+14	+5	0,2	2,5	2,5
10	18	+17	+6		3	3
18	30	+20	+7		4	4
30	50	+25	+9		4	4
50	80	+29	+10		5	5
80	120	+34	+12	0,3	6	6

^a Roundness is measured using the least squares centre (LSC) method according to ISO 4291 and ISO 1101.

^b Alternative: cylindricity in accordance with ISO 1101.

Table A.2 — Tolerances for shaft raceway

Tolerance values in micrometres

Nominal shaft raceway diameter mm		Deviation of shaft raceway diameter			Surface roughness R_a max.	Roundness ^a	Variation of mean diameter ^b
>	≤	Tolerance class	high	low		IT3	IT3
						max.	max.
3	6	h5	0	-5	0,2	2,5	2,5
6	10	h5	0	-6		2,5	2,5
10	18	h5	0	-8		3	3
18	30	h5	0	-9		4	4
30	50	h5	0	-11		4	4
50	80	h5	0	-13		5	5
		g5	-10	-23			
80	120	g5	-12	-27	0,3	6	6

NOTE For alternate tolerance class g5 for nominal shaft raceway diameter between 51 mm and 80 mm, provide higher clearance; in case of doubt, consult the bearing manufacturer.

^a Roundness is measured using the least squares centre (LSC) method according to ISO 4291 and ISO 1101.

^b Alternative: cylindricity in accordance with ISO 1101.

A.3 Tolerances for raceway widths

See Figure A.1.

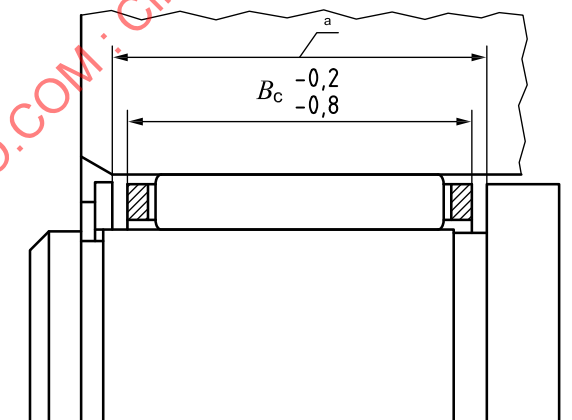

^a Distance between axial guidance surfaces.

Figure A.1 — Tolerances for raceway widths

The raceway width and the distance between the axial guidance surfaces are at least equal to the nominal cage width, B_c . Deviations of distance between axial guidance surfaces and surface roughness of axial guidance surfaces are shown in Table A.3.