**Cards and security devices for
personal identification — Contactless
proximity objects —**

**Part 2:
Radio frequency power and signal
interface**

*Cartes et dispositifs de sécurité pour l'identification personnelle —
Objets sans contact de proximité —*

Partie 2: Interface radiofréquence et des signaux de communication

STANDARDSISO.COM : Click to view the full PDF of ISO/IEC 14443-2:2020



STANDARDSISO.COM : Click to view the full PDF of ISO/IEC 14443-2:2020



COPYRIGHT PROTECTED DOCUMENT

© ISO/IEC 2020

All rights reserved. Unless otherwise specified, or required in the context of its implementation, no part of this publication may be reproduced or utilized otherwise in any form or by any means, electronic or mechanical, including photocopying, or posting on the internet or an intranet, without prior written permission. Permission can be requested from either ISO at the address below or ISO's member body in the country of the requester.

ISO copyright office
CP 401 • Ch. de Blandonnet 8
CH-1214 Vernier, Geneva
Phone: +41 22 749 01 11
Email: copyright@iso.org
Website: www.iso.org

Published in Switzerland

Contents

	Page
Foreword	iv
Introduction	v
1 Scope	1
2 Normative references	1
3 Terms and definitions	1
4 Symbols and abbreviated terms	2
5 General considerations	5
5.1 Initial dialogue	5
5.2 Compliance	5
5.2.1 PICC compliance	5
5.2.2 PCD compliance	5
6 Power transfer	6
6.1 General	6
6.2 Frequency	6
6.3 Operating field strength	6
7 Signal interface	7
8 Communication signal interface Type A	9
8.1 Communication PCD to PICC	9
8.1.1 Bit rate	9
8.1.2 Modulation	9
8.1.3 Bit representation and coding	18
8.2 Communication PICC to PCD	23
8.2.1 Bit rate	23
8.2.2 PICC load modulation transmission	23
8.2.3 Subcarrier	27
8.2.4 Subcarrier modulation	28
8.2.5 PCD load modulation reception	28
8.2.6 Bit representation and coding	32
9 Communication signal interface Type B	32
9.1 Communication PCD to PICC	32
9.1.1 Bit rate	32
9.1.2 Modulation for bit rates of $f_c/128$, $f_c/64$, $f_c/32$, $f_c/16$, $f_c/8$, $f_c/4$, and $f_c/2$	33
9.1.3 Bit representation and coding	41
9.2 Communication PICC to PCD	41
9.2.1 Bit rate	41
9.2.2 PICC load modulation transmission	42
9.2.3 Subcarrier	42
9.2.4 Subcarrier modulation	42
9.2.5 PCD load modulation reception	42
9.2.6 Bit representation and coding	42
10 Electromagnetic disturbance levels	42
10.1 PCD limits	42
10.2 PICC limits	42
Annex A (informative) Complex envelope and constellation diagram	44
Annex B (informative) Inter symbol interference	45
Bibliography	47

Foreword

ISO (the International Organization for Standardization) and IEC (the International Electrotechnical Commission) form the specialized system for worldwide standardization. National bodies that are members of ISO or IEC participate in the development of International Standards through technical committees established by the respective organization to deal with particular fields of technical activity. ISO and IEC technical committees collaborate in fields of mutual interest. Other international organizations, governmental and non-governmental, in liaison with ISO and IEC, also take part in the work.

The procedures used to develop this document and those intended for its further maintenance are described in the ISO/IEC Directives, Part 1. In particular, the different approval criteria needed for the different types of document should be noted. This document was drafted in accordance with the editorial rules of the ISO/IEC Directives, Part 2 (see www.iso.org/directives).

Attention is drawn to the possibility that some of the elements of this document may be the subject of patent rights. ISO and IEC shall not be held responsible for identifying any or all such patent rights. Details of any patent rights identified during the development of the document will be in the Introduction and/or on the ISO list of patent declarations received (see www.iso.org/patents) or the IEC list of patent declarations received (see <http://patents.iec.ch>).

Any trade name used in this document is information given for the convenience of users and does not constitute an endorsement.

For an explanation of the voluntary nature of standards, the meaning of ISO specific terms and expressions related to conformity assessment, as well as information about ISO's adherence to the World Trade Organization (WTO) principles in the Technical Barriers to Trade (TBT) see www.iso.org/iso/foreword.html.

This document was prepared by Joint Technical Committee ISO/IEC JTC 1, *Information technology*, Subcommittee SC 17, *Cards and security devices for personal identification*.

This fourth edition cancels and replaces the third edition (ISO/IEC 14443-2:2016), which has been technically revised.

The main changes compared to the previous edition are as follows:

- amendment of active and passive PICC transmissions;
- amendment of electromagnetic disturbance levels for all PICC classes.

A list of all parts in the ISO/IEC 14443 series can be found on the ISO website.

Any feedback or questions on this document should be directed to the user's national standards body. A complete listing of these bodies can be found at www.iso.org/members.html.

Introduction

ISO/IEC 14443 (all parts) is one of a group of International Standards describing the parameters for identification cards as defined in ISO/IEC 7810 and the use of such cards for international interchange.

This document describes the electrical characteristics of two types of contactless interface between a proximity card and a proximity coupling device. The interface includes both power and bi-directional communication. It is intended to be used in conjunction with other parts of the ISO/IEC 14443 series.

Contactless card standards cover a variety of types as embodied in ISO/IEC 10536 (all parts) (close-coupled cards), ISO/IEC 14443 (all parts) (proximity cards), and ISO/IEC 15693 (all parts) (vicinity cards). These are intended for operation when very near, nearby and at a longer distance from associated coupling devices, respectively.

STANDARDSISO.COM : Click to view the full PDF of ISO/IEC 14443-2:2020

STANDARDSISO.COM : Click to view the full PDF of ISO/IEC 14443-2:2020

Cards and security devices for personal identification — Contactless proximity objects —

Part 2: Radio frequency power and signal interface

1 Scope

This document specifies the characteristics of the fields to be provided for power and bi-directional communication between proximity coupling devices (PCDs) and proximity cards or objects (PICCs).

This document does not specify the means of generating coupling fields, nor the means of compliance with electromagnetic radiation and human exposure regulations, which can vary depending on the country.

2 Normative references

The following documents are referred to in the text in such a way that some or all of their content constitutes requirements of this document. For dated references, only the edition cited applies. For undated references, the latest edition of the referenced document (including any amendments) applies.

ISO/IEC 10373-6, *Cards and security devices for personal identification — Test methods — Part 6: Contactless proximity objects*

ISO/IEC 14443-1:2018, *Cards and security devices for personal identification — Contactless proximity objects — Part 1: Physical characteristics*

ISO/IEC 14443-3:2018, *Cards and security devices for personal identification — Contactless proximity objects — Part 3: Initialization and anticollision*

3 Terms and definitions

For the purposes of this document, the following terms and definitions apply.

ISO and IEC maintain terminological databases for use in standardization at the following addresses:

- ISO Online browsing platform: available at <https://www.iso.org/obp>
- IEC Electropedia: available at <http://www.electropedia.org/>

3.1

bit duration

time during which a logic level is defined, at the end of which a new bit starts

3.2

BPSK

phase shift keying where the phase shift is 180°, resulting in two phase state possibilities

3.3

modified Miller

method of bit coding whereby a logic level during a *bit duration* (3.1) is represented by the position of a pulse within the bit frame

**3.4
modulation index**

m
 $[1 - b] / [1 + b]$, where b is the ratio between the modulated amplitude and the initial signal amplitude

Note 1 to entry: The value of the index may be expressed as a percentage.

**3.5
NRZ-L**

method of bit coding whereby a logic level during a *bit duration* (3.1) is represented by one of two defined physical states of a communication medium

**3.6
operating volume**

positions, for each PICC class, where the corresponding Reference PICC and Active Reference PICC show PCD compliance with all requirements of this document for this class

**3.7
subcarrier**

signal of frequency, f_s , used to modulate a carrier of frequency, f_c

**3.8
Manchester**

method of bit coding whereby a logic level during a *bit duration* (3.1) is represented by a sequence of two defined physical states of a communication medium, the order of the physical states within the sequence defining the logical state

**3.9
TR0**

guard time between the end of a PCD transmission and the start of the PICC *subcarrier* (3.7) generation

**3.10
TR1**

synchronization time between the start of the PICC *subcarrier* (3.7) generation and the start of the PICC subcarrier modulation

4 Symbols and abbreviated terms

a	pulse shape factor, Type A
ACP	actual constellation point
AP	actual phase value
ASK	amplitude shift keying
b	ratio between the modulated and initial signal amplitude, Type B
BPSK	binary phase shift keying
EMD	electromagnetic disturbance, parasitically generated by the PICC
EPI	elementary phase interval
etu	elementary time unit
f_c	frequency of operating field (carrier frequency)
f_s	frequency of subcarrier

H	equivalent homogenous magnetic field strength
H_{INITIAL}	field strength of the unmodulated RF field
h_{OVS}	envelope overshoot for bit rates of $f_c/64$, $f_c/32$, and $f_c/16$, Type A
h_f	envelope undershoot, Type B
h_r	envelope overshoot, Type B
ISI	inter symbol interference
ISI_d	inter symbol interference angle
ISI_m	inter symbol interference magnitude
MS1	first modulated state
MS2	second modulated state
NP	nominal phase value
NRZ-L	non-return to zero (L for level)
OOK	on/off keying
PauseA	PCD modulation pulse, Type A
ϑ_0	initial phase of the subcarrier
ϑ_{LM}	load modulation phase
$\vartheta_{\text{LM, INIT}}$	initial value of $\vartheta_{\text{LM, MEAN}}$
$\vartheta_{\text{LM, INTER}}$	load modulation interstate phase drift
$\vartheta_{\text{LM, INTER, PCD}}$	limit of $\vartheta_{\text{LM, INTER}}$ for PCD reception
$\vartheta_{\text{LM, INTER, PICC}}$	limit of $\vartheta_{\text{LM, INTER}}$ for PICC transmission
$\vartheta_{\text{LM, INTRA}}$	load modulation intrastate phase drift
$\vartheta_{\text{LM, INTRA, PCD}}$	limit of $\vartheta_{\text{LM, INTRA}}$ for PCD reception
$\vartheta_{\text{LM, INTRA, PICC}}$	limit of $\vartheta_{\text{LM, INTRA}}$ for PICC transmission
$\vartheta_{\text{LM, MEAN}}$	interstate phase
PCD	proximity coupling device
PICC	proximity card or object
P_H	complex constellation point of the maximum NP
P_L	complex constellation point of the minimum NP
PNP	previous nominal phase
PR	phase range
PSK	phase shift keying

RF	radio frequency
t_1	PauseA length
t_2	PauseA "Low" time for a bit rate of $f_c/128$
t_3	PauseA rise time for a bit rate of $f_c/128$
t_4	PauseA rise time section for a bit rate of $f_c/128$
t_5	PauseA "Low" time for bit rates of $f_c/64$, $f_c/32$, and $f_c/16$
t_6	PauseA rise time for bit rates of $f_c/64$, $f_c/32$, and $f_c/16$
$t_{6, \text{max, PCD}}$	maximum value of t_6 for PCD transmission
$t_{6, \text{max, PICC}}$	maximum value of t_6 for PICC reception
t_b	bit duration, Type A
t_f	envelope fall time, Type B
$t_{f, \text{max, PCD}}$	maximum fall time for PCD transmission, Type B
$t_{f, \text{max, PICC}}$	maximum fall time for PICC reception, Type B
t_r	envelope rise time, Type B
$t_{r, \text{max, PCD}}$	maximum rise time for PCD transmission, Type B
$t_{r, \text{max, PICC}}$	maximum rise time for PICC reception, Type B
t_x	pulse position, Type A
US	unmodulated state
$V_{ \text{MS1-US} }$	modulus of the difference between US and any MS1
$V_{E, \text{PCD}}$	EMD limit, PCD
$V_{E, \text{PICC}}$	EMD limit, PICC
V_{LMA}	load modulation amplitude
$V_{\text{LMA, min, PCD}}$	minimum limit of V_{LMA} for PCD reception
$V_{\text{LMA, min, PICC}}$	minimum limit of V_{LMA} for PICC transmission
$V_{\text{LMA, max, PCD}}$	maximum limit of V_{LMA} for PCD reception
$V_{\text{LMA, max, PICC}}$	maximum limit of V_{LMA} for PICC transmission
#	Number

5 General considerations

5.1 Initial dialogue

The initial dialogue between the PCD and the PICC shall be conducted through the following consecutive operations:

- activation of the PICC by the RF operating field of the PCD;
- the PICC shall wait silently for a command from the PCD;
- transmission of a command by the PCD;
- transmission of a response by the PICC.

These operations shall use the RF power and signal interface specified in [Clauses 6 to 10](#).

5.2 Compliance

5.2.1 PICC compliance

The PICC shall comply with all mandatory requirements of this document and may support optional requirements (bit rate, class, etc.). The PICC should fulfill all the requirements of one particular class in order to improve interoperability.

5.2.2 PCD compliance

5.2.2.1 General

The PCD shall comply with all mandatory requirements of this document and may support optional requirements (bit rate, support of PICCs of optional classes, etc.).

The PCD

- shall support PICCs of "Class 1", "Class 2", and "Class 3",
- may optionally support PICCs of "Class 4",
- may optionally support PICCs of "Class 5", and
- may optionally support PICCs of "Class 6".

PCD requirements measured with Reference PICCs 1, 2, and 3 and Active Reference PICCs 1, 2, and 3 are mandatory for all PCDs.

PCD requirements measured with Reference PICC 4 and Active Reference PICC 4 are only mandatory for PCDs supporting operation with "Class 4" PICCs.

PCD requirements measured with Reference PICC 5 and Active Reference PICC 5 are only mandatory for PCDs supporting operation with "Class 5" PICCs.

PCD requirements measured with Reference PICC 6 and Active Reference PICC 6 are only mandatory for PCDs supporting operation with "Class 6" PICCs.

For each supported PICC class, the PCD manufacturer shall indicate the operating volume within which the PCD fulfills all requirements of this document.

5.2.2.2 PCD supporting PICCs of particular class(es)

If a PCD is expected to operate with PICCs of only particular class(es), it is not mandatory for this PCD to support PICCs of other classes. This PCD shall comply with all requirements of this document non-specific to one class. The PCD manufacturer shall clearly state which class(es) are supported.

NOTE A PCD which does not support all mandatory classes 1, 2, and 3 is not fully compliant with this document. It can be advertised as "supporting 'Class X' PICCs only" or "compliant with Class(es) X requirements only".

6 Power transfer

6.1 General

The PCD shall produce a high frequency alternating magnetic field. This field inductively couples to the PICC to transfer power and is modulated for communication.

6.2 Frequency

The frequency, f_c , of the RF operating field shall be 13,56 MHz \pm 7 kHz.

6.3 Operating field strength

Within the manufacturer specified operating volumes (see 3.6), the PCD shall generate a field strength of at least H_{min} and not exceeding H_{max} under unmodulated conditions, see Table 1.

The PCD

- shall support PICCs of "Class 1", "Class 2", and "Class 3",
- may optionally support PICCs of "Class 4",
- may optionally support PICCs of "Class 5", and
- may optionally support PICCs of "Class 6".

PCD requirements measured with Reference PICCs 1, 2, and 3 are mandatory for all PCDs.

PCD requirements measured with Reference PICC 4 are only mandatory for PCDs supporting operation with "Class 4" PICCs.

PCD requirements measured with Reference PICC 5 are only mandatory for PCDs supporting operation with "Class 5" PICCs.

PCD requirements measured with Reference PICC 6 are only mandatory for PCDs supporting operation with "Class 6" PICCs.

Table 1 — PCD field strength

	H_{min} A/m (rms)	H_{max} A/m (rms)
Measured with Reference PICC 1	1,5	7,5
Measured with Reference PICC 2	1,5	8,5
Measured with Reference PICC 3	1,5	8,5
Measured with Reference PICC 4 (optional)	2,0	12
Measured with Reference PICC 5 (optional)	2,5	14
Measured with Reference PICC 6 (optional)	4,5	18

The PCD shall not generate a field strength higher than the average and maximum levels specified for all mandatory and optional classes in ISO/IEC 14443-1:2018, 4.4 (alternating magnetic field) in any possible PICC position and orientation, measured with the associated Reference PICCs.

Test methods for the PCD operating field are defined in ISO/IEC 10373-6 and use a dedicated Reference PICC for each class.

If the PICC meets the requirements of one particular class as specified in ISO/IEC 14443-1, then the PICC shall operate as intended continuously between H_{\min} and H_{\max} defined for its class, see [Table 2](#); this includes all PICC requirements defined in this document and processing of the manufacturer specified set of commands.

If the PICC does not claim to meet the requirements of one particular class as specified in ISO/IEC 14443-1, then:

- if the PICC antenna fits within the external rectangle defined in "Class 2" as specified in ISO/IEC 14443-1, then
 - the PICC shall operate as intended continuously between H_{\min} and H_{\max} defined for "Class 2", see [Table 2](#),
 - the PICC shall pass the loading effect test defined for "Class 2";
- if the PICC antenna fits within the external rectangle or external circle defined in "Class 3" as specified in ISO/IEC 14443-1, then
 - the PICC shall operate as intended continuously between H_{\min} and H_{\max} defined for "Class 3", see [Table 2](#),
 - the PICC shall pass the loading effect test defined for "Class 3";
- if the PICC antenna does not claim to fit within the external rectangle or external circle defined in "Class 2" or "Class 3" as specified in ISO/IEC 14443-1, then
 - the PICC shall operate as intended continuously between H_{\min} and H_{\max} defined for "Class 1", see [Table 2](#),
 - the PICC shall pass the loading effect test defined for "Class 1".

NOTE 1 If the PICC does not claim to meet the requirements of one particular class, then the requirements defined above are sufficient to guarantee proper operation and interoperability with PCDs.

Table 2 — PICC operating field strength

	H_{\min} A/m (rms)	H_{\max} A/m (rms)
"Class 1" PICC	1,5	7,5
"Class 2" PICC	1,5	8,5
"Class 3" PICC	1,5	8,5
"Class 4" PICC	2,0	12
"Class 5" PICC	2,5	14
"Class 6" PICC	4,5	18

NOTE 2 Margins of field strength are effectively included by the test methods as specified in ISO/IEC 10373-6.

7 Signal interface

In order to transmit data to the PICC, the PCD modulates the amplitude of its alternating magnetic field strength with modulation pulses.

In order to transmit data to the PCD, the PICC passively loads the PCD alternating magnetic field and/or actively contributes with its own alternating magnetic field. This is called load modulation.

Within the manufacturer specified operating volumes (see 3.6), the PCD shall generate modulation pulses as described in Clauses 8 and 9 and shall be capable of receiving the minimum load modulation amplitude.

NOTE 1 As an indication of the operating volume, the manufacturer can give the operating range (e.g. 0 to X cm) within which all requirements of this document are fulfilled.



Test methods for the PCD communication signal interface are defined in ISO/IEC 10373-6.

Two communication signal interfaces, Type A and Type B, are described in Clauses 8 and 9. The PCD shall alternate between modulation methods when idling before detecting the presence of a PICC of Type A or Type B.

Only one communication signal interface may be active during a communication session until deactivation by the PCD or removal of the PICC. Subsequent session(s) may then proceed with either modulation method.

Table 3 and Table 4 illustrate the concepts described in Clauses 8 and 9.

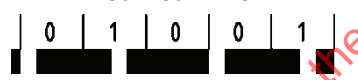
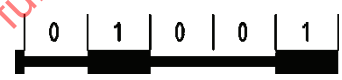
Table 3 — Example PCD to PICC communication signals for Type A and Type B interfaces

	Type A	Type B
bit rates of $f_c/128, f_c/64, f_c/32, \text{ and } f_c/16$	ASK ~ 100 % modified Miller 	ASK ~ 10 % NRZ-L 
bit rates of $f_c/8, f_c/4, \text{ and } f_c/2$	ASK ~ 10 % NRZ-L 	
bit rates of $3f_c/4, f_c, 3f_c/2, \text{ and } 2f_c$	PSK, see 8.1.2.5.	

NOTE 2 For the coding of modified Miller, see 8.1.3.1.

Table 4 — Example PICC to PCD communication signals for Type A and Type B interfaces

	Type A	Type B
bit rate of $f_c/128$	Load modulation Subcarrier $f_c/16$ OOK Manchester 	Load modulation Subcarrier $f_c/16$ BPSK NRZ-L 
bit rate of $f_c/64$	Load modulation Subcarrier $f_c/16$ BPSK NRZ-L 	

Table 4 (continued)

	Type A	Type B
bit rate of $f_c/32$	Load modulation Subcarrier $f_c/16$ BPSK NRZ-L 	
bit rates of $f_c/16, f_c/8, f_c/4,$ and $f_c/2$	Load modulation Subcarrier equals the bit rate BPSK NRZ-L 	

8 Communication signal interface Type A

8.1 Communication PCD to PICC

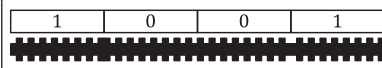
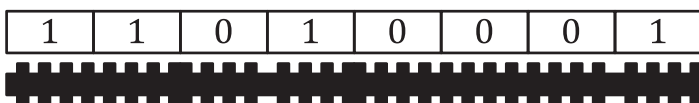
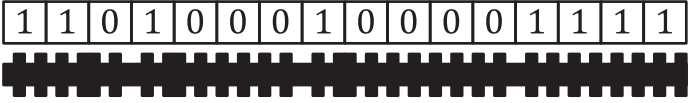
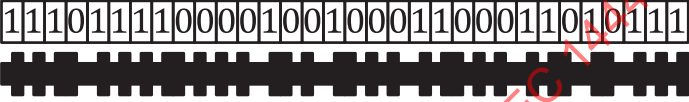
8.1.1 Bit rate

The bit rate for the transmission during initialization and anticollision shall be $f_c/128$ (~106 kbit/s).

The bit rate for the transmission after initialization and anticollision shall be one of the following:

- $f_c/128$ (~106 kbit/s);
- $f_c/64$ (~212 kbit/s);
- $f_c/32$ (~424 kbit/s);
- $f_c/16$ (~848 kbit/s);
- $f_c/8$ (~1,70 Mbit/s);
- $f_c/4$ (~3,39 Mbit/s);
- $f_c/2$ (~6,78 Mbit/s);
- $3f_c/4$ (~10,17 Mbit/s);
- f_c (~13,56 Mbit/s);
- $3f_c/2$ (~20,34 Mbit/s);
- $2f_c$ (~27,12 Mbit/s).

8.1.2 Modulation

8.1.2.1 General

[8.1.2.2](#) to [8.1.2.5](#) describe the modulation waveform requirements for all bit rates.

NOTE Filtering of the PCD modulation is defined in ISO/IEC 10373-6. Some extreme values can be filtered out. This can affect the relevant timing parameter associated with the fall and rise timings as well as overshoot and undershoot values.

8.1.2.2 Modulation for a bit rate of $f_c/128$

Communication from PCD to PICC for a bit rate of $f_c/128$ shall use the modulation principle of ASK 100 % of the RF operating field to create a PauseA as shown in Figure 1.

The envelope of the PCD field shall decrease monotonically to less than 5 % of its initial value $H_{INITIAL}$ and remain less than 5 % for t_2 . This envelope shall comply with Figure 1.

If the envelope of the PCD field does not decrease monotonically, the time between a local maximum and the time of passing the same value before the local maximum shall not exceed 0,5 μs . This shall only apply if the local maximum is greater than 5 % of $H_{INITIAL}$.

The PauseA length t_1 is the time between 90 % of the falling edge and 5 % of the rising edge of the H-field signal envelope.

In case of an overshoot, the field shall remain within 90 % of $H_{INITIAL}$ and 110 % of $H_{INITIAL}$.

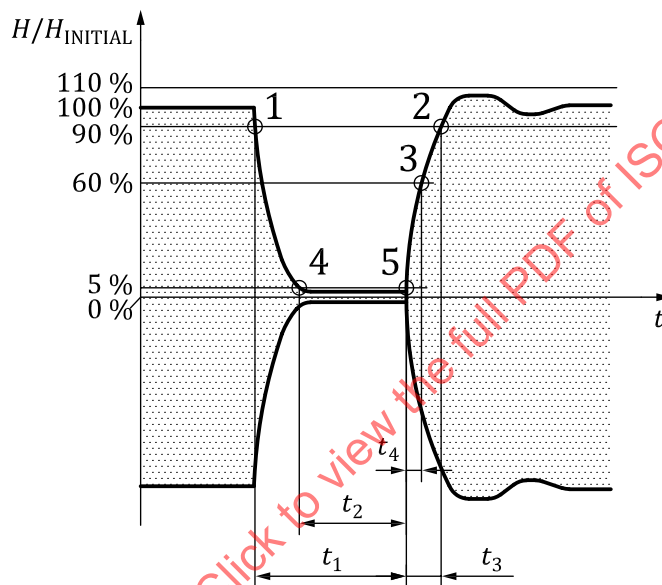

Key

- 1 start of t_1
- 2 end of t_3
- 3 end of t_4
- 4 start of t_2
- 5 end of t_1 and t_2 , start of t_3 and t_4

Figure 1 — PauseA for a bit rate of $f_c/128$

The PCD shall generate a PauseA with timing parameters defined in Table 5.

Table 5 — PCD transmission: PauseA timing parameters for a bit rate of $f_c/128$

Parameter	Condition	Minimum	Maximum
t_1		$28/f_c$	$40,5/f_c$
t_2	$t_1 > 34/f_c$	$7/f_c$	t_1
	$t_1 \leq 34/f_c$	$10/f_c$	
t_3		$1,5 \times t_4$	$16/f_c$
t_4		0	$6/f_c$

PCD implementations may be restricted to generate a PauseA with values of $t_1 = n/f_c$ ($n = \text{integer}$). Therefore, measurement of t_1 should be rounded to the closest n in the unit $1/f_c$.

NOTE 1 The maximum value of t_2 is a function of the measured value of t_1 .

NOTE 2 The minimum value of t_3 is a function of the measured value of t_4 .

The PICC shall be able to receive a PauseA with timing parameters defined in [Table 6](#).

Table 6 — PICC reception: PauseA timing parameters for a bit rate of $f_c/128$

Parameter	Condition	Minimum	Maximum
t_1		$27,5/f_c$	$41/f_c$
t_2	$t_1 > 34/f_c$	$6/f_c$	t_1
	$t_1 \leq 34/f_c$	$9/f_c$	
t_3		$1,5 \times t_4$	$17/f_c$
t_4		0	$7/f_c$

NOTE 3 The maximum value of t_2 is a function of the set value of t_1 .

NOTE 4 The minimum value of t_3 is a function of the set value of t_4 .

For a bit rate of $f_c/128$, the PCD shall generate a PauseA with a rise time t_3

- greater than both $0/f_c$ and $(t_1 - t_2) - 24,5/f_c$, and
- less than both $(t_1 - t_2) + 7/f_c$ and $16/f_c$.

For a bit rate of $f_c/128$, the PICC shall be able to receive a PauseA with a rise time t_3

- greater than both $0/f_c$ and $(t_1 - t_2) - 26/f_c$, and
- less than both $(t_1 - t_2) + 8/f_c$ and $17/f_c$.

NOTE 5 Minimum and maximum values of $(t_1 - t_2)$ are derived from minimum and maximum values of t_1 and t_2 defined in [Table 5](#) and [Table 6](#).

The timing parameters for PCD and PICC are illustrated in [Figure 2](#).

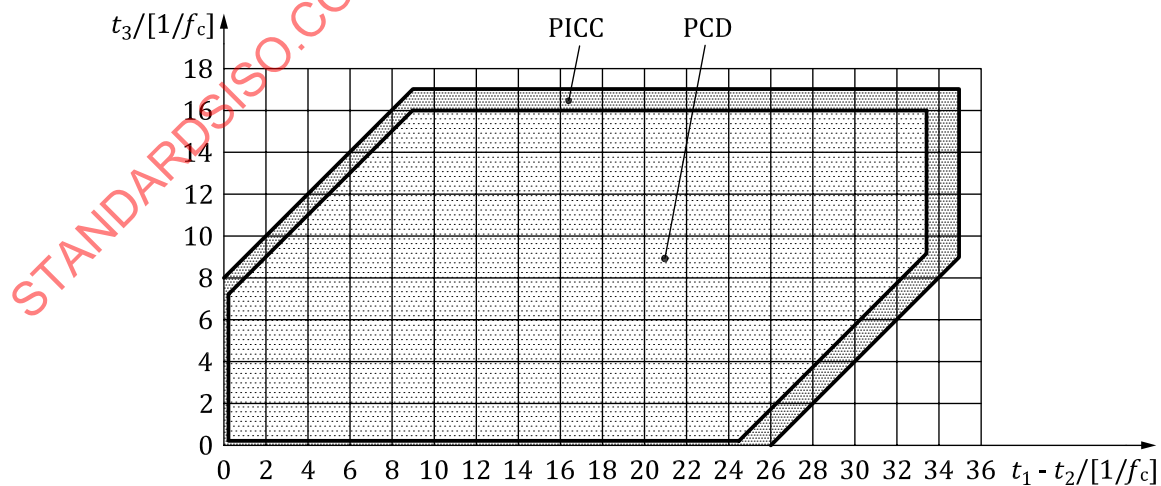
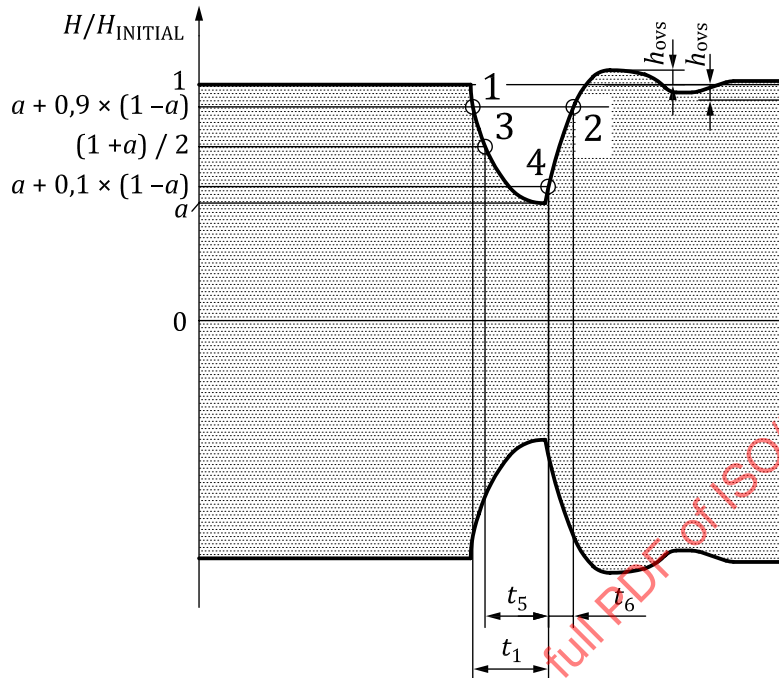

Figure 2 — PauseA timing parameters for a bit rate of $f_c/128$

8.1.2.3 Modulation for bit rates of $f_c/64$, $f_c/32$, and $f_c/16$

Communication from PCD to PICC for bit rates of $f_c/64$ (~212 kbit/s), $f_c/32$ (~424 kbit/s), and $f_c/16$ (~848 kbit/s) shall use the modulation principle of ASK (with different values for "a") of the operating field strength to create a PauseA as shown in Figure 3.



Key

- 1 start of t_1
- 2 end of t_6
- 3 start of t_5
- 4 end of t_1 and t_5 , start of t_6

Figure 3 — PauseA for bit rates of $f_c/64$, $f_c/32$, and $f_c/16$

The envelope of the PCD field shall decrease monotonically to the maximum value of parameter "a" as defined in Table 7. Then, if the envelope evolution becomes non-monotonic, the difference between any local maximum and the lowest previous minimum (within the same PauseA) shall not exceed 0,09 times the difference between the initial amplitude and the previous lowest minimum.

The parameter "a" is the lowest minimum within PauseA.

In case of an overshoot, the field shall remain within $H_{INITIAL} \times (1 - h_{ovs})$ and $H_{INITIAL} \times (1 + h_{ovs})$.

The PCD shall generate a PauseA with timing and amplitude parameters defined in Table 7.

Table 7 — PCD transmission: PauseA parameters for bit rates of $f_c/64$, $f_c/32$, and $f_c/16$

Parameter	Bit rate	Minimum	Maximum
a	$f_c/64$	0	0,18
	$f_c/32$	0	0,38
	$f_c/16$	0,22	0,58
t_1	$f_c/64$	$16,5/f_c$	$20/f_c$
	$f_c/32$	$8,0/f_c$	$10/f_c$
	$f_c/16$	$4,0/f_c$	$5/f_c$

Table 7 (continued)

Parameter	Bit rate	Minimum	Maximum
t_5	$f_c/64$	$t_1/2 + 4/f_c$	t_1
	$f_c/32$	$t_1/2 + 1/f_c$	t_1
	$f_c/16$	$t_1/2$	t_1
t_6	$f_c/64$	See requirements above Figure 4	
	$f_c/32$	See requirements above Figure 5	
	$f_c/16$	See requirements above Figure 6	
h_{ovs}	$f_c/64, f_c/32,$ and $f_c/16$	0	$[1 - t_6 / (2 \times t_{6, \max, PCD})] \times 0,10 \times (1 - a)$

NOTE 1 The minimum and maximum values of t_5 are functions of the measured value of t_1 .

NOTE 2 The maximum value of h_{ovs} for PCD transmission is a function of the measured value of t_6 and of $t_{6, \max, PCD}$ (see requirements above [Figure 4](#), [Figure 5](#), or [Figure 6](#)).

PCD implementations may be restricted to generate a PauseA with values of $t_1 = n/f_c$ ($n = \text{integer}$). Therefore, measurement of t_1 should be rounded to the closest n in the unit $1/f_c$.

The PICC shall be able to receive a PauseA with timing and amplitude parameters defined in [Table 8](#).

Table 8 — PICC reception: PauseA parameters for bit rates of $f_c/64, f_c/32,$ and $f_c/16$

Parameter	Bit rate	Min	Max
a	$f_c/64$	0	0,2
	$f_c/32$	0	0,4
	$f_c/16$	0,2	0,6
t_1	$f_c/64$	$16/f_c$	$20/f_c$
	$f_c/32$	$8/f_c$	$10/f_c$
	$f_c/16$	$4/f_c$	$5/f_c$
t_5	$f_c/64$	$t_1/2 + 3/f_c$	t_1
	$f_c/32$	$t_1/2 + 1/f_c$	t_1
	$f_c/16$	$t_1/2$	t_1
t_6	$f_c/64$	See requirements above Figure 4	
	$f_c/32$	See requirements above Figure 5	
	$f_c/16$	See requirements above Figure 6	
h_{ovs}	$f_c/64, f_c/32,$ and $f_c/16$	0	$[1 - t_6 / (2 \times t_{6, \max, PICC})] \times 0,11 \times (1 - a)$

NOTE 3 The minimum and maximum values of t_5 are functions of the set value of t_1 .

NOTE 4 The maximum value of h_{ovs} for PICC reception is a function of the set value of t_6 and of $t_{6, \max, PICC}$ (see requirements above [Figure 4](#), [Figure 5](#), or [Figure 6](#)).

NOTE 5 The PauseA length t_1 is the time between an envelope amplitude of $[a + 0,9 \times (1 - a)]$ on the falling edge and $[a + 0,1 \times (1 - a)]$ on the rising edge.

For a bit rate of $f_c/64$, the PCD shall generate a PauseA with a rise time t_6

- greater than both $0/f_c$ and $(t_1 - t_5) - 3/f_c$, and
- less than both $(t_1 - t_5) + 8/f_c$ and $t_{6, \max, PCD} = 11/f_c$.

For a bit rate of $f_c/64$, the PICC shall be able to receive a PauseA with a rise time t_6

- greater than both $0/f_c$ and $(t_1 - t_5) - 4/f_c$, and

— less than both $(t_1 - t_5) + 9/f_c$ and $t_{6, \max, \text{PICC}} = 12/f_c$.

NOTE 6 Minimum and maximum values of $(t_1 - t_5)$ are derived from minimum and maximum values of t_1 and t_5 defined in Table 7 and Table 8.

The timing parameters for PCD and PICC are illustrated in Figure 4.

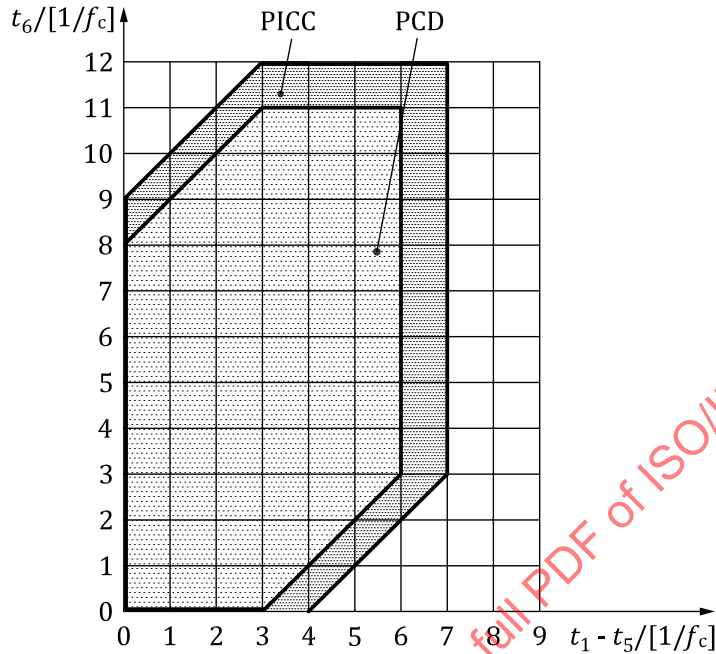

Figure 4 — PauseA timing parameters for a bit rate of $f_c/64$

For a bit rate of $f_c/32$, the PCD shall generate a PauseA with a rise time t_6

- greater than $0/f_c$, and
- less than both $(t_1 - t_5) + 8/f_c$ and $t_{6, \max, \text{PCD}} = 9/f_c$.

For a bit rate of $f_c/32$, the PICC shall be able to receive a PauseA with a rise time t_6

- greater than $0/f_c$, and
- less than both $(t_1 - t_5) + 8/f_c$ and $t_{6, \max, \text{PICC}} = 10/f_c$.

The timing parameters for PCD and PICC are illustrated in Figure 5.

NOTE 7 Minimum and maximum values of $(t_1 - t_5)$ are derived from minimum and maximum values of t_1 and t_5 defined in Table 7 and Table 8.

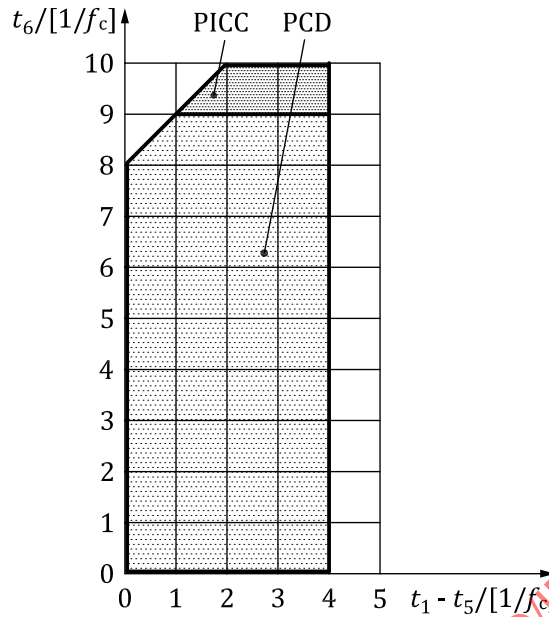

Figure 5 — PauseA timing parameters for a bit rate of $f_c/32$

For a bit rate of $f_c/16$, the PCD shall generate a PauseA with a rise time t_6

- greater than $0/f_c$ and
- less than both $(t_1 - t_5) + 4/f_c$ and $t_{6, \max, PCD} = 5,5/f_c$.

For a bit rate of $f_c/16$ the PICC shall be able to receive a PauseA with a rise time t_6

- greater than $0/f_c$ and
- less than both $(t_1 - t_5) + 4,5/f_c$ and $t_{6, \max, PICC} = 6/f_c$.

NOTE 8 Minimum and maximum values of $(t_1 - t_5)$ are derived from minimum and maximum values of t_1 and t_5 defined in Table 7 and Table 8.

The timing parameters for PCD and PICC are illustrated in Figure 6.

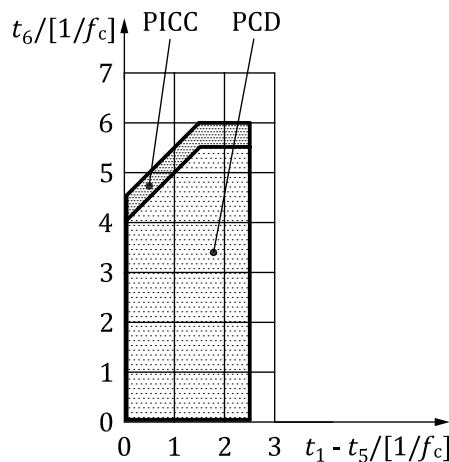

Figure 6 — PauseA timing parameters for a bit rate of $f_c/16$

8.1.2.4 Modulation for bit rates of $f_c/8$, $f_c/4$, and $f_c/2$

See 9.1.2.

8.1.2.5 Modulation for bit rates of $3f_c/4$, f_c , $3f_c/2$, and $2f_c$

For communication from PCD to PICC using bit rates of $3f_c/4$, f_c , $3f_c/2$, and $2f_c$, information is encoded by PSK modulation of RF carrier of the operating field.

For bit rates of $3f_c/4$, f_c , $3f_c/2$, and $2f_c$, information is encoded by PSK modulation of the RF carrier. The RF carrier is phase modulated with an NP at each etu. For each bit rate, the length of an etu and the number of NPs are specified in Table 9.

Table 9 — etu and number of NPs

Bit rate	etu	number of NPs
$3f_c/4$ (~10,17 Mbit/s)	$4/f_c$	8
f_c (~13,56 Mbit/s)	$4/f_c$	16
$3f_c/2$ (~20,34 Mbit/s)	$2/f_c$	8
$2f_c$ (~27,12 Mbit/s)	$2/f_c$	16

The difference between two consecutive NPs is defined as EPI, specified in Table 10 and illustrated in Figure 7.

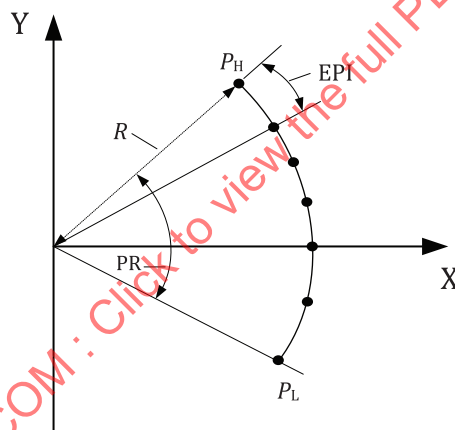

Key

- X real
- Y imaginary
- nominal constellation point
- R the signal amplitude

Figure 7 — Nominal constellation points

Table 10 — EPI

Bit rate	EPI
$3f_c/4$ (~10,17 Mbit/s)	8°
f_c (~13,56 Mbit/s)	4°
$3f_c/2$ (~20,34 Mbit/s)	8°
$2f_c$ (~27,12 Mbit/s)	4°

The difference between the angle of P_H and the angle of P_L defines the phase range PR as illustrated in [Figure 7](#). The PCD and PICC shall respect the PR limits as specified in [Table 11](#) and [Table 12](#).

Table 11 — PR for PCD transmission

Bit rate	Minimum PR	Maximum PR
$3f_c/4, 3f_c/2$	54°	58°
$f_c, 2f_c$	58°	62°

Table 12 — PR for PICC reception

Bit rate	Minimum PR	Maximum PR
$3f_c/4, 3f_c/2$	52°	60°
$f_c, 2f_c$	56°	64°

Due to the limited bandwidth channel, the intended nominal phase modulation is affected by inter symbol interference (ISI) resulting in an ACP at the end of each etu. The angle of the ACP is defined as AP. This is described in a constellation diagram with ISI_m and ISI_d as specified below in [Table 13](#) and [Table 14](#) and illustrated in [Figure 8](#).

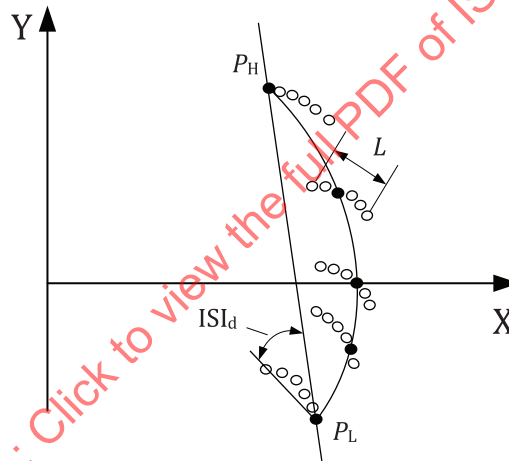

Key

- X real
- Y imaginary
- nominal constellation point
- actual constellation point

Figure 8 — Actual constellation points

NOTE See [Annex A](#) for explanation on constellation diagrams. See [Annex B](#) for explanation on ISI.

L The maximum distance of any two ACPs related to the same NP.

ISI_d The rotation of all ACPs modulations related to one NP. It is defined as the angle between the line through P_H, P_L and the line through any 2 ACPs with maximum distance related to the same NP.

ISI_m The ISI magnitude normalized to the EPI. $ISI_m = \arcsin(L/R)/EPI$. The PCD and PICC shall respect ISI_m limits for all ACPs as a function of ISI_d as specified in [Table 13](#) and [Table 14](#), and illustrated in [Figure 9](#).

Table 13 — ISI_m limits for PCD transmission

	Condition	Minimum	Maximum
ISI _m	abs(ISI _d) ≤ 90°	0	1,5 - abs(ISI _d)/90°
	abs(ISI _d) > 90°	0	0,5

Table 14 — ISI_m limits for PICC reception

	Condition	Minimum	Maximum
ISI _m	abs(ISI _d) ≤ 90°	0	1,6 - abs(ISI _d)/90°
	abs(ISI _d) > 90°	0	0,6

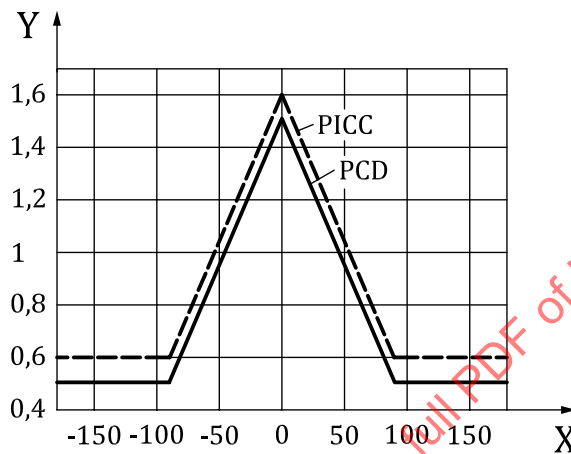

Key

- X ISI_d [°]
- Y ISI_m [EPI]

Figure 9 — Maximum ISI_m limits for PCD and PICC

APs may vary randomly due to phase noise. The instantaneous phase error caused by noise is defined as the difference between the AP and the NP of 0° of an unmodulated signal sampled at the end of each etu. The differential phase error is defined as the difference of two consecutive instantaneous phase errors.

The normalized differential phase noise is the rms value of the differential phase error divided by EPI.

The normalized differential phase noise shall be lower than 0,033 for PCD transmission and lower than 0,035 for PICC reception.

8.1.3 Bit representation and coding

8.1.3.1 Bit representation and coding for bit rates of $f_c/128$, $f_c/64$, $f_c/32$, and $f_c/16$

The following sequences are defined:

- sequence X: after a time of half the bit duration (t_x), a PauseA shall occur;
- sequence Y: for the full bit duration (t_b), no modulation shall occur;
- sequence Z: at the beginning of the bit duration (t_b), a PauseA shall occur.

Figure 10, together with the timing parameters in Table 15, illustrates sequences X, Y, and Z.

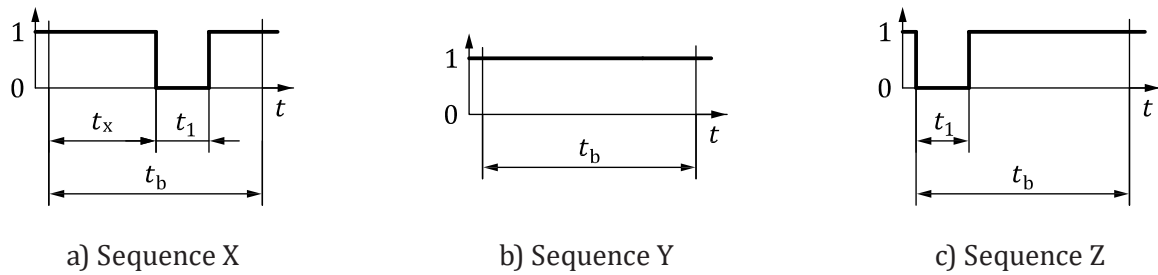
**Key**

- 0 modulation
1 no modulation

Figure 10 — Sequences for Type A communication PCD to PICC (logical modulation signal)**Table 15 — Parameters for sequences**

Parameter	Bit rate			
	$f_c/128$	$f_c/64$	$f_c/32$	$f_c/16$
t_b	$128/f_c$	$64/f_c$	$32/f_c$	$16/f_c$
t_x	$64/f_c$	$32/f_c$	$16/f_c$	$8/f_c$
t_1	see t_1 of Table 5		see t_1 of Table 7	

The above sequences shall be used to code the following information:

- logic "1": sequence X;
- logic "0": sequence Y with the following two exceptions:
 - i) if there are two or more contiguous "0"s, sequence Z shall be used from the second "0" on;
 - ii) if the first bit after a "start of communication" is "0", sequence Z shall be used to represent this and any "0"s which follow directly thereafter.
- start of communication: sequence Z;
- end of communication: logic "0" followed by sequence Y;
- no information: at least two sequences Y.

8.1.3.2 Bit representation and coding for bit rates of $f_c/8$, $f_c/4$, and $f_c/2$

Bit representation and coding is defined in [9.1.3](#).

Start of communication shall be as defined in ISO/IEC 14443-3:2018, 7.1.4.

End of communication shall be as defined in ISO/IEC 14443-3:2018, 7.1.5.

8.1.3.3 Bit representation and coding for bit rates of $3f_c/4$ and $3f_c/2$

For start of communication, the PCD shall generate a sequence of 140 NPs starting with NP of etu #1 as specified in [Table 16](#). The phase of the unmodulated RF carrier is defined as NP = 0°.

Table 16 — Start of communication for bit rates of $3f_c/4$ and $3f_c/2$

etu #	NP	etu #	NP	etu #	NP	etu #	NP	etu #	NP	etu #	NP	etu #	NP
1	24°	21	24°	41	24°	61	-24°	81	-16°	101	8°	121	-24°
2	24°	22	24°	42	24°	62	24°	82	24°	102	32°	122	32°
3	-24°	23	-24°	43	-24°	63	32°	83	-16°	103	8°	123	-24°
4	-24°	24	-24°	44	-24°	64	8°	84	-8°	104	-16°	124	32°
5	24°	25	24°	45	24°	65	-8°	85	16°	105	-16°	125	-24°
6	24°	26	24°	46	-24°	66	16°	86	-16°	106	24°	126	8°
7	-24°	27	-24°	47	24°	67	8°	87	24°	107	24°	127	24°
8	-24°	28	-24°	48	-24°	68	-8°	88	8°	108	32°	128	16°
9	24°	29	24°	49	32°	69	16°	89	0°	109	-16°	129	0°
10	24°	30	24°	50	32°	70	8°	90	32°	110	0°	130	16°
11	-24°	31	-24°	51	-24°	71	-16°	91	16°	111	32°	131	24°
12	-24°	32	-24°	52	8°	72	32°	92	32°	112	-16°	132	-8°
13	24°	33	24°	53	-16°	73	-24°	93	-16°	113	8°	133	-24°
14	24°	34	24°	54	24°	74	16°	94	-16°	114	-8°	134	0°
15	-24°	35	-24°	55	-8°	75	8°	95	-24°	115	-16°	135	32°
16	-24°	36	-24°	56	8°	76	8°	96	32°	116	24°	136	8°
17	24°	37	24°	57	-16°	77	-24°	97	-8°	117	24°	137	8°
18	24°	38	24°	58	16°	78	-16°	98	-24°	118	24°	138	16°
19	-24°	39	-24°	59	16°	79	0°	99	8°	119	16°	139	8°
20	-24°	40	-24°	60	16°	80	-8°	100	-24°	120	-16°	140	0°

For transmission of each binary information symbol the PCD shall generate a NP as specified in [Table 17](#) as a function of the symbol to be sent and the PNP.

For encoding the first symbol the PCD shall use PNP = 0° (last NP of [Table 16](#)).

Table 17 — NP encoding for bit rates of $3f_c/4$ and $3f_c/2$

Symbol MSB LSB	PNP	32°	24°	16°	8°	0°	-8°	-16°	-24°
000	NP	32°	24°	16°	8°	0°	-8°	-16°	-24°
001		24°	16°	8°	0°	-8°	-16°	-24°	32°
010		8°	0°	-8°	-16°	-24°	32°	24°	16°
011		16°	8°	0°	-8°	-16°	-24°	32°	24°
100		-24°	32°	24°	16°	8°	0°	-8°	-16°
101		-16°	-24°	32°	24°	16°	8°	0°	-8°
110		0°	-8°	-16°	-24°	32°	24°	16°	8°
111		-8°	-16°	-24°	32°	24°	16°	8°	0°

For reception of binary information symbols, the PICC shall decode the information symbol as specified in [Table 18](#) as a function of the received NP and the PNP.

For decoding the first symbol, the PICC shall use PNP = 0°.

Table 18 — NP decoding for bit rates of $3f_c/4$ and $3f_c/2$

NP	PNP	32°	24°	16°	8°	0°	-8°	-16°	-24°
32°	Symbol	000	100	101	111	110	010	011	001
24°		001	000	100	101	111	110	010	011
16°		011	001	000	100	101	111	110	010
8°		010	011	001	000	100	101	111	110
0°		110	010	011	001	000	100	101	111
-8°		111	110	010	011	001	000	100	101
-16°		101	111	110	010	011	001	000	100
-24°		100	101	111	110	010	011	001	000

8.1.3.4 Bit representation and coding for bit rates of f_c and $2f_c$

For start of communication, the PCD shall generate a sequence of 140 NPs, starting with NP of etu #1 as specified in [Table 19](#). The phase of the unmodulated RF carrier is defined as NP = 0°.

Table 19 — Start of communication for bit rates of f_c and $2f_c$

etu #	NP	etu #	NP	etu #	NP	etu #	NP	etu #	NP	etu #	NP	etu #	NP
1	28°	21	28°	41	28°	61	-4°	81	32°	101	-20°	121	-28°
2	28°	22	28°	42	28°	62	-20°	82	8°	102	4°	122	32°
3	-28°	23	-28°	43	-28°	63	-12°	83	-28°	103	-16°	123	-28°
4	-28°	24	-28°	44	-28°	64	28°	84	-16°	104	28°	124	32°
5	28°	25	28°	45	28°	65	16°	85	12°	105	32°	125	-28°
6	28°	26	28°	46	-28°	66	-20°	86	-16°	106	8°	126	4°
7	-28°	27	-28°	47	28°	67	-24°	87	28°	107	12°	127	24°
8	-28°	28	-28°	48	-28°	68	24°	88	16°	108	20°	128	16°
9	28°	29	28°	49	32°	69	-12°	89	8°	109	-24°	129	0°
10	28°	30	28°	50	32°	70	-20°	90	-20°	110	-4°	130	20°
11	-28°	31	-28°	51	-28°	71	20°	91	32°	111	32°	131	32°
12	-28°	32	-28°	52	8°	72	4°	92	-12°	112	-16°	132	4°
13	28°	33	28°	53	-12°	73	16°	93	4°	113	8°	133	-12°
14	28°	34	28°	54	32°	74	-8°	94	4°	114	-8°	134	12°
15	-28°	35	-28°	55	0°	75	-16°	95	-4°	115	-12°	135	-20°
16	-28°	36	-28°	56	16°	76	-16°	96	-12°	116	32°	136	24°
17	28°	37	28°	57	-8°	77	16°	97	16°	117	-28°	137	28°
18	28°	38	28°	58	28°	78	28°	98	4°	118	-24°	138	-24°
19	-28°	39	-28°	59	32°	79	-20°	99	-28°	119	-28°	139	-28°
20	-28°	40	-28°	60	-28°	80	-28°	100	8°	120	8°	140	32°

For transmission of each binary information symbol, the PCD shall generate an NP as specified in [Table 20](#) as a function of the symbol to be sent and the PNP.

For encoding of the first symbol, the PCD shall use PNP = 32° (last NP of [Table 19](#)).

Table 20 — NP encoding for bit rates of f_c and $2f_c$

Symbol MSB LSB	PNP	32°	28°	24°	20°	16°	12°	8°	4°	0°	-4°	-8°	-12°	-16°	-20°	-24°	-28°
0000	NP	32°	28°	24°	20°	16°	12°	8°	4°	0°	-4°	-8°	-12°	-16°	-20°	-24°	-28°
0001		28°	24°	20°	16°	12°	8°	4°	0°	-4°	-8°	-12°	-16°	-20°	-24°	-28°	32°
0010		20°	16°	12°	8°	4°	0°	-4°	-8°	-12°	-16°	-20°	-24°	-28°	32°	28°	24°
0011		24°	20°	16°	12°	8°	4°	0°	-4°	-8°	-12°	-16°	-20°	-24°	-28°	32°	28°
0100		4°	0°	-4°	-8°	-12°	-16°	-20°	-24°	-28°	32°	28°	24°	20°	16°	12°	8°
0101		8°	4°	0°	-4°	-8°	-12°	-16°	-20°	-24°	-28°	32°	28°	24°	20°	16°	12°
0110		16°	12°	8°	4°	0°	-4°	-8°	-12°	-16°	-20°	-24°	-28°	32°	28°	24°	20°
0111		12°	8°	4°	0°	-4°	-8°	-12°	-16°	-20°	-24°	-28°	32°	28°	24°	20°	16°
1000		-28°	32°	28°	24°	20°	16°	12°	8°	4°	0°	-4°	-8°	-12°	-16°	-20°	-24°
1001		-24°	-28°	32°	28°	24°	20°	16°	12°	8°	4°	0°	-4°	-8°	-12°	-16°	-20°
1010		-16°	-20°	-24°	-28°	32°	28°	24°	20°	16°	12°	8°	4°	0°	-4°	-8°	-12°
1011		-20°	-24°	-28°	32°	28°	24°	20°	16°	12°	8°	4°	0°	-4°	-8°	-12°	-16°
1100		0°	-4°	-8°	-12°	-16°	-20°	-24°	-28°	32°	28°	24°	20°	16°	12°	8°	4°
1101		-4°	-8°	-12°	-16°	-20°	-24°	-28°	32°	28°	24°	20°	16°	12°	8°	4°	0°
1110		-12°	-16°	-20°	-24°	-28°	32°	28°	24°	20°	16°	12°	8°	4°	0°	-4°	-8°
1111		-8°	-12°	-16°	-20°	-24°	-28°	32°	28°	24°	20°	16°	12°	8°	4°	0°	-4°

For reception of binary information symbols, the PICC shall decode the information symbol as specified in Table 21 as a function of the received nominal phase value NP and the previous received nominal phase PNP.

To decode the first symbol after the start of communication, PNP = 32° shall be used.

Table 21 — NP decoding for bit rates of f_c and $2f_c$

NP	PNP	32°	28°	24°	20°	16°	12°	8°	4°	0°	-4°	-8°	-12°	-16°	-20°	-24°	-28°
32°	Sym- bol	0000	1000	1001	1011	1010	1110	1111	1101	1100	0100	0101	0111	0110	0010	0011	0001
28°		0001	0000	1000	1001	1011	1010	1110	1111	1101	1100	0100	0101	0111	0110	0010	0011
24°		0011	0001	0000	1000	1001	1011	1010	1110	1111	1101	1100	0100	0101	0111	0110	0010
20°		0010	0011	0001	0000	1000	1001	1011	1010	1110	1111	1101	1100	0100	0101	0111	0110
16°		0110	0010	0011	0001	0000	1000	1001	1011	1010	1110	1111	1101	1100	0100	0101	0111
12°		0111	0110	0010	0011	0001	0000	1000	1001	1011	1010	1110	1111	1101	1100	0100	0101
8°		0101	0111	0110	0010	0011	0001	0000	1000	1001	1011	1010	1110	1111	1101	1100	0100
4°		0100	0101	0111	0110	0010	0011	0001	0000	1000	1001	1011	1010	1110	1111	1101	1100
0°		1100	0100	0101	0111	0110	0010	0011	0001	0000	1000	1001	1011	1010	1110	1111	1101
-4°		1101	1100	0100	0101	0111	0110	0010	0011	0001	0000	1000	1001	1011	1010	1110	1111
-8°		1111	1101	1100	0100	0101	0111	0110	0010	0011	0001	0000	1000	1001	1011	1010	1110
-12°		1110	1111	1101	1100	0100	0101	0111	0110	0010	0011	0001	0000	1000	1001	1011	1010
-16°		1010	1110	1111	1101	1100	0100	0101	0111	0110	0010	0011	0001	0000	1000	1001	1011
-20°		1011	1010	1110	1111	1101	1100	0100	0101	0111	0110	0010	0011	0001	0000	1000	1001
-24°		1001	1011	1010	1110	1111	1101	1100	0100	0101	0111	0110	0010	0011	0001	0000	1000
-28°		1000	1001	1011	1010	1110	1111	1101	1100	0100	0101	0111	0110	0010	0011	0001	0000

8.2 Communication PICC to PCD

8.2.1 Bit rate

The bit rate for the transmission during initialization and anticollision shall be $f_c/128$ (~106 kbit/s).

The bit rate for the transmission after initialization and anticollision shall be one of the following:

- $f_c/128$ (~106 kbit/s);
- $f_c/64$ (~212 kbit/s);
- $f_c/32$ (~424 kbit/s);
- $f_c/16$ (~848 kbit/s);
- $f_c/8$ (~1,70 Mbit/s);
- $f_c/4$ (~3,39 Mbit/s);
- $f_c/2$ (~6,78 Mbit/s).

8.2.2 PICC load modulation transmission

8.2.2.1 General

The PICC shall be capable to communicate to the PCD via inductive coupling. The field generated by the PCD shall be passively and/or actively modified by the PICC with a subcarrier signal of frequency f_s .

The modification of the PCD field by the PICC is called load modulation.

The PICC transmits data by generating different states corresponding to different modifications of the PCD field. Within the instantaneous load modulation signal over time, three dedicated states are defined:

- US: unmodulated state, just before the first modulated state MS1,
- MS1: first modulated state to produce the load modulation,
- MS2: second modulated state to produce the load modulation (may be equal to US).

The PICC starts load modulation transmission by producing MS1.

[Figure 11](#) depicts exemplarily the complex constellation plot with respect to the PCD field, with occurrences of all three generated states US, MS1, and MS2, as well as transition paths between some of these states. Transition paths are parts of the instantaneous load modulation that occur between states and are not taken into account in this document. MS1 and MS2 persist during a certain time period. The start and end of each occurrence of all states, and their amplitude and phase measurements are defined in ISO/IEC 10373-6.

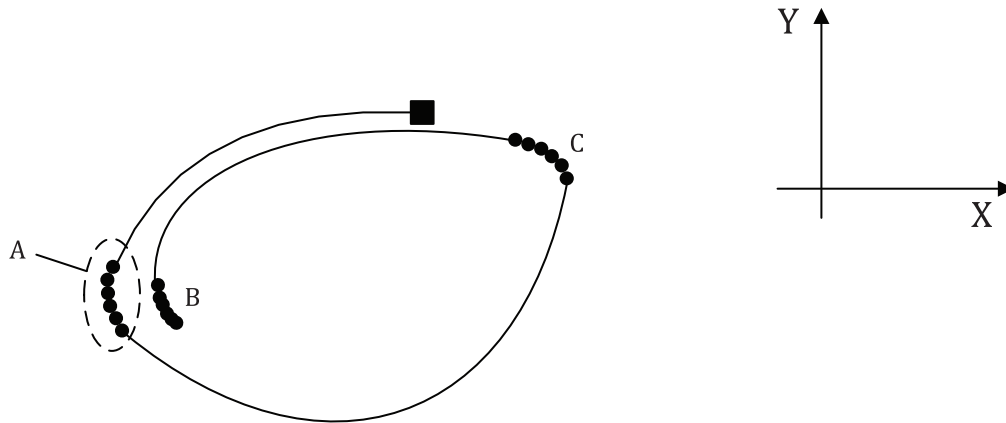

Key

- one small section of the instantaneous load modulation during an occurrence of MS1 or MS2
- unmodulated state US
- transitions paths
- A first occurrence of MS1
- B occurrences of MS1
- C occurrence of MS2
- Y quadrature
- X in phase (H_{PCD})

Figure 11 — Constellation plot during part of the PICC response, depicting US, MS1, and MS2

8.2.2.2 Amplitude Requirements

If the PICC meets the requirements of one particular class as specified in ISO/IEC 14443-1, then the load modulation amplitude of the PICC shall be between $V_{LMA, min, PICC}$ and $V_{LMA, max, PICC}$ specified for its class when measured as described in ISO/IEC 10373-6, using the Test PCD assembly defined for its class, where H is the value of magnetic field strength in A/m (rms).

If the PICC does not claim to meet the requirements of one particular class as specified in ISO/IEC 14443-1, then the load modulation amplitude of the PICC shall be between $V_{LMA, min, PICC}$ and $V_{LMA, max, PICC}$ specified for "Class 1" when measured as described in ISO/IEC 10373-6, using the Test PCD assembly defined for "Class 1", where H is the value of magnetic field strength in A/m (rms).

Table 22 specifies for each PICC class both the load modulation amplitude limits and the relevant Test PCD assembly to measure the load modulation amplitude.

Table 22 — Load modulation amplitude limits for PICC transmission

	$V_{LMA, min, PICC}$ mV (peak)	$V_{LMA, max, PICC}$ mV (peak)	Test PCD assembly
"Class 1" PICC	$22/H^{0,5}$	100 mV	Test PCD assembly 1
"Class 2" PICC	Min(14 ; $22/H^{0,5}$)	90 mV	Test PCD assembly 1
"Class 3" PICC	Min(14 ; $22/H^{0,5}$)	80 mV	Test PCD assembly 1
"Class 4" PICC	Min(18 ; $40/H^{0,5}$)	100 mV	Test PCD assembly 2
"Class 5" PICC	Min(14 ; $34/H^{0,5}$)	90 mV	Test PCD assembly 2
"Class 6" PICC	Min(7 ; $26/H^{0,5}$)	80 mV	Test PCD assembly 2

NOTE 1 $V_{LMA, min, PICC}$ was named $V_{LMA, PICC}$ in all previous editions of this document.

The modulus of the difference between US and any instantaneous value of any occurrence of MS1 is named $V_{|MS1-US|}$ and shall be at least $V_{LMA, min, PICC}$ as defined in Table 22 and illustrated in Figure 12.

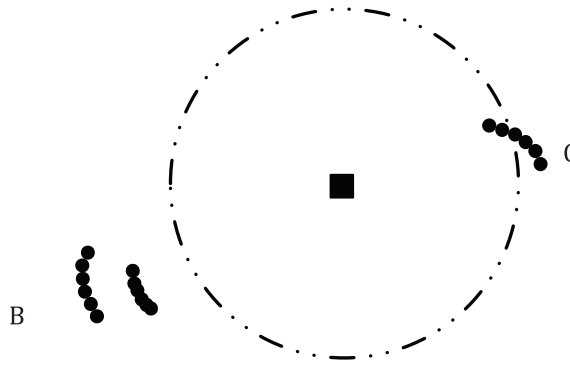

Key

- one small section of an occurrence of MS1 or MS2
- - - - $V_{LMA, min, PICC}$ limit
- unmodulated state US
- B occurrences of MS1
- C occurrence of MS2

Figure 12 — Constellation plot during part of the PICC response, depicting $V_{LMA, min, PICC}$ limit

NOTE 2 $V_{LMA, min, PICC}$ is the limit for two requirements, V_{LMA} and $V_{|MS1-US|}$, as respectively defined in Table 22 and illustrated in Figure 12.

8.2.2.3 Phase requirements

For each subcarrier period:

- ϑ_{LM} is defined as the argument of all differences between sections in the occurrence of MS1 and the corresponding sections in the occurrence of MS2 in the same subcarrier period, as illustrated in Figure 13,
- there is an absolute maximum and an absolute minimum of ϑ_{LM} ; ϑ'_{LM} is defined as the one which occurs first in time, ϑ''_{LM} is the one which occurs secondly, then
- $\Delta\vartheta_{LM} = \vartheta''_{LM} - \vartheta'_{LM}$.

Figure 14 is an illustration of ϑ_{LM} , ϑ'_{LM} , ϑ''_{LM} , and $\Delta\vartheta_{LM}$.

The intrastate phase drift is the maximum of ϑ_{LM} variation and is defined as:

$$\vartheta_{LM, INTRA} = \max(\max(\Delta\vartheta_{LM}); 0) - \min(\min(\Delta\vartheta_{LM}); 0),$$

where $\max(\Delta\vartheta_{LM})$ and $\min(\Delta\vartheta_{LM})$ are the maximum and minimum of $\Delta\vartheta_{LM}$ computed over all occurrences of all subcarrier periods, respectively.

For PICC to PCD bit rates using a subcarrier higher than $f_c/16$, $\phi_{LM, INTRA}$ should be less than $\phi_{LM, INTRA, max, PICC}$.

For each subcarrier period, $\phi_{LM, MEAN}$ is defined as the argument of the difference between

- the average complex value of the occurrence of MS1, and
- the average complex value of the occurrence of MS2,

as illustrated in [Figure 15](#).

The interstate phase drift is the maximum $\phi_{LM, MEAN}$ variation and is defined as:

- $\phi_{LM, INTER} = \max(\phi_{LM, MEAN}) - \min(\phi_{LM, MEAN})$.

NOTE There is no requirement on the initial value, i.e. first element, of $\phi_{LM, MEAN}$.

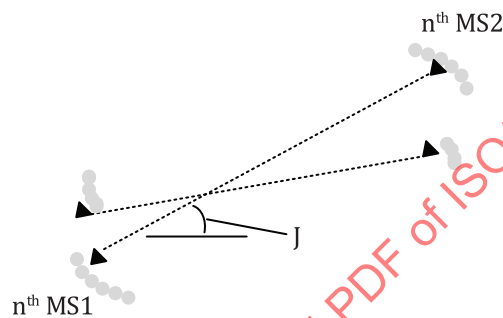

Key

- ▲ one averaged MS1 or MS2 (averaging is defined in ISO/IEC 10373-6)
- one small section of the instantaneous load modulation during a defined state
- J $\phi_{LM, MEAN}$ for the n^{th} subcarrier period

Figure 15 — Constellation plot during part of the PICC response, depicting $\phi_{LM, MEAN}$

For PICC to PCD bit rates using a subcarrier of $f_c/16$, $\phi_{LM, INTER}$ shall be less than $\phi_{LM, INTER, max, PICC} = 30^\circ$.

For PICC to PCD bit rates using a subcarrier higher than $f_c/16$, $\phi_{LM, INTER}$ should be less than $\phi_{LM, INTER, max, PICC}$.

8.2.3 Subcarrier

8.2.3.1 General

The PICC shall generate a load modulation signal only when data is to be transmitted.

8.2.3.2 Subcarrier for bit rates of $f_c/128$, $f_c/64$, $f_c/32$, and $f_c/16$

The frequency, f_s , of the subcarrier shall be $f_c/16$ (~848 kHz). Consequently, during initialization and anticollision, one bit duration is equivalent to 8 subcarrier periods. After initialization and anticollision, the number of subcarrier periods is determined by the bit rate.

8.2.3.3 Subcarrier for bit rates of $f_c/8$, $f_c/4$, and $f_c/2$

The frequency, f_s , of the subcarrier shall be $f_c/8$ (~1,70 MHz), $f_c/4$ (~3,39 MHz), or $f_c/2$ (~6,78 MHz) depending on the bit rate as specified in [Table 23](#).

Table 23 — Subcarrier frequency vs. bit rate

Bit rate	Subcarrier frequency
$f_c/8$ (~1,70 Mbit/s)	$f_c/8$
$f_c/4$ (~3,39 Mbit/s)	$f_c/4$
$f_c/2$ (~6,78 Mbit/s)	$f_c/2$

8.2.4 Subcarrier modulation

At the bit rate of $f_c/128$, the subcarrier is modulated using OOK with the sequences defined in 8.2.6.1. At bit rates of $f_c/64$, $f_c/32$, $f_c/16$, $f_c/8$, $f_c/4$, and $f_c/2$, the subcarrier is modulated using BPSK with the sequences defined in 8.2.6.2.

8.2.5 PCD load modulation reception

8.2.5.1 Amplitude requirements

The PCD shall be able to receive at least a load modulation amplitude between $V_{LMA, min, PCD}$ and $V_{LMA, max, PCD}$ when measured as described in ISO/IEC 10373-6, using the test setup as defined in Table 24, with Active Reference PICCs 1, 2, and 3, where H is the value of magnetic field strength in A/m (rms).

If the PCD supports operation with "Class 4" PICCs, it shall be able to receive at least a load modulation amplitude between $V_{LMA, min, PCD}$ and $V_{LMA, max, PCD}$ when measured as described in ISO/IEC 10373-6, using the test setup as defined in Table 24, with Active Reference PICC 4, where H is the value of magnetic field strength in A/m (rms).

If the PCD supports operation with "Class 5" PICCs, it shall be able to receive at least a load modulation amplitude between $V_{LMA, min, PCD}$ and $V_{LMA, max, PCD}$ when measured as described in ISO/IEC 10373-6, using the test setup as defined in Table 24, with Active Reference PICC 5, where H is the value of magnetic field strength in A/m (rms).

If the PCD supports operation with "Class 6" PICCs, it shall be able to receive at least a load modulation amplitude between $V_{LMA, min, PCD}$ and $V_{LMA, max, PCD}$ when measured as described in ISO/IEC 10373-6, using the test setup as defined in Table 24, with Active Reference PICC 6, where H is the value of magnetic field strength in A/m (rms).

Table 24 specifies for each Active Reference PICC the load modulation amplitude limits for PCD reception and the Test PCD assembly to use to measure the PCD sensitivity.

Table 24 — Load modulation amplitude limits for PCD reception

PICC Class	$V_{LMA, min, PCD}$ mV (peak)	$V_{LMA, max, PCD}$ mV (peak)	Subcarrier frequency	Reference PICC	Test PCD assembly
1	$20/H^{0,5}$	110 mV	$f_c/16$	Active Reference PICC 1	Test PCD assembly 1
			$>f_c/16$	Reference PICC 1	
2	Min(12,5 ; $20/H^{0,5}$)	100 mV	$f_c/16$	Active Reference PICC 2	Test PCD assembly 1
			$>f_c/16$	Reference PICC 1	
3	Min(12,5 ; $20/H^{0,5}$)	90 mV	$f_c/16$	Active Reference PICC 3	Test PCD assembly 1
			$>f_c/16$	Reference PICC 1	
4 (optional)	Min(16 ; $36/H^{0,5}$)	110 mV	$f_c/16$	Active Reference PICC 4	Test PCD assembly 2
			$>f_c/16$	Reference PICC 1	
5 (optional)	Min(13 ; $31/H^{0,5}$)	100 mV	$f_c/16$	Active Reference PICC 5	Test PCD assembly 2
			$>f_c/16$	Reference PICC 1	

Table 24 (continued)

PICC Class	$V_{LMA, \min, PCD}$ mV (peak)	$V_{LMA, \max, PCD}$ mV (peak)	Subcarrier frequency	Reference PICC	Test PCD assembly
6 (optional)	Min(6 ; 23/H ^{0.5})	90 mV	$f_c/16$	Active Reference PICC 6	Test PCD assembly 2
			$>f_c/16$	Reference PICC 1	

NOTE $V_{LMA, \min, PCD}$ was named $V_{LMA, PCD}$ in all previous editions of this document.

Figure 16, Figure 17, Figure 18, Figure 19, and Figure 20 are illustrations of the PCD and PICC minimum load modulation amplitude limits for each class.

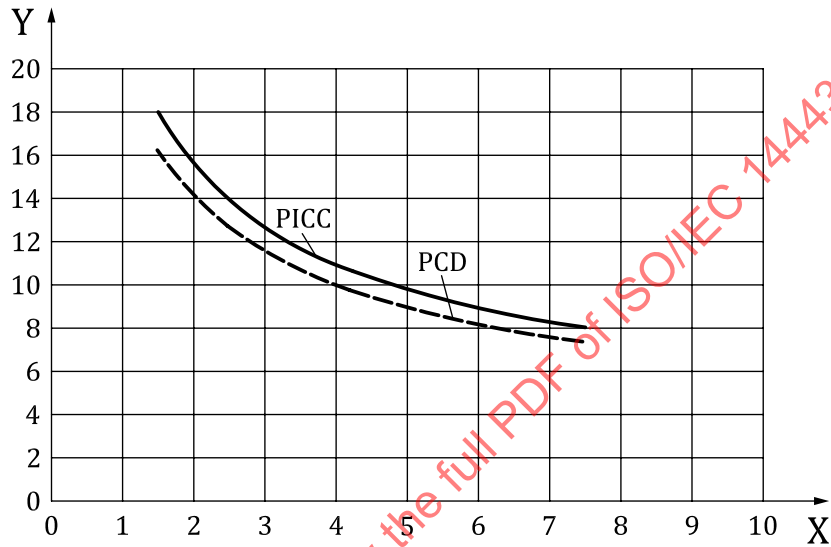

Key

- X field strength [A/m (rms)]
- Y load modulation amplitude [mV (peak)]

Figure 16 — Minimum load modulation amplitude for "Class 1"

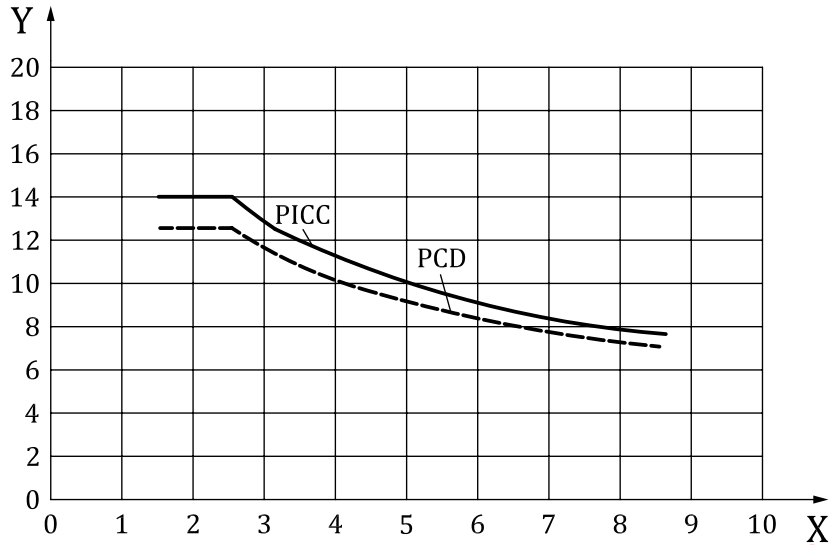

Key

- X field strength [A/m (rms)]
- Y load modulation amplitude [mV (peak)]

Figure 17 — Minimum load modulation amplitude for "Class 2" and "Class 3"

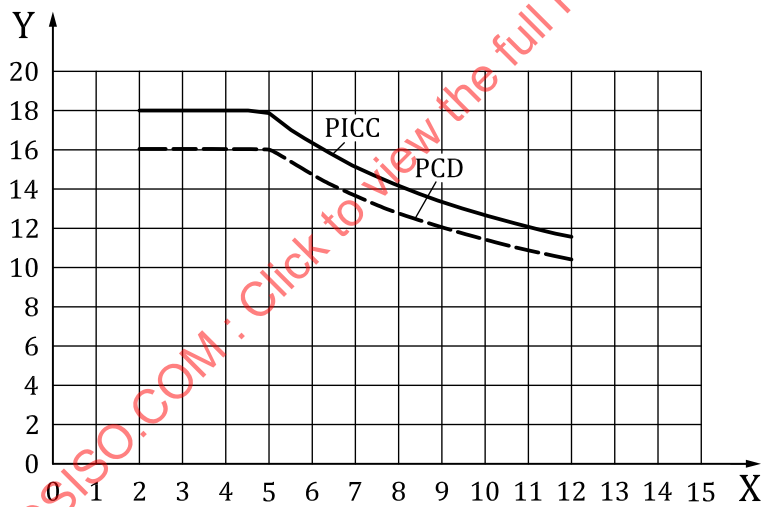

Key

- X field strength [A/m (rms)]
- Y load modulation amplitude [mV (peak)]

Figure 18 — Minimum load modulation amplitude for "Class 4"

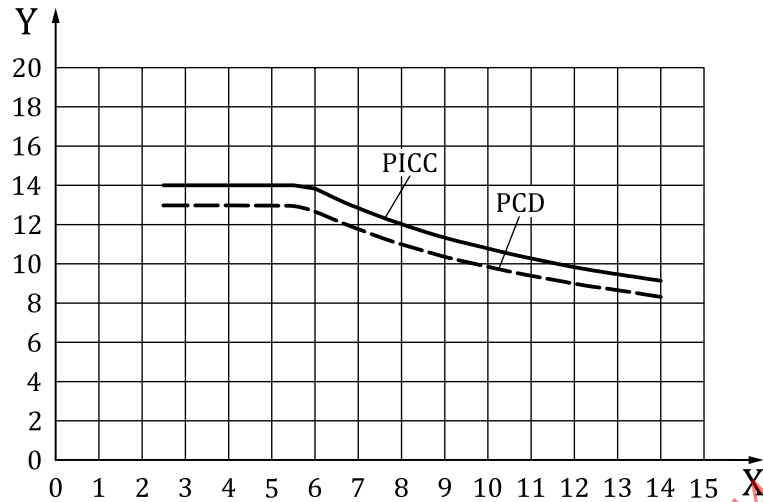

Key

- X field strength [A/m (rms)]
- Y load modulation amplitude [mV (peak)]

Figure 19 — Minimum load modulation amplitude for "Class 5"

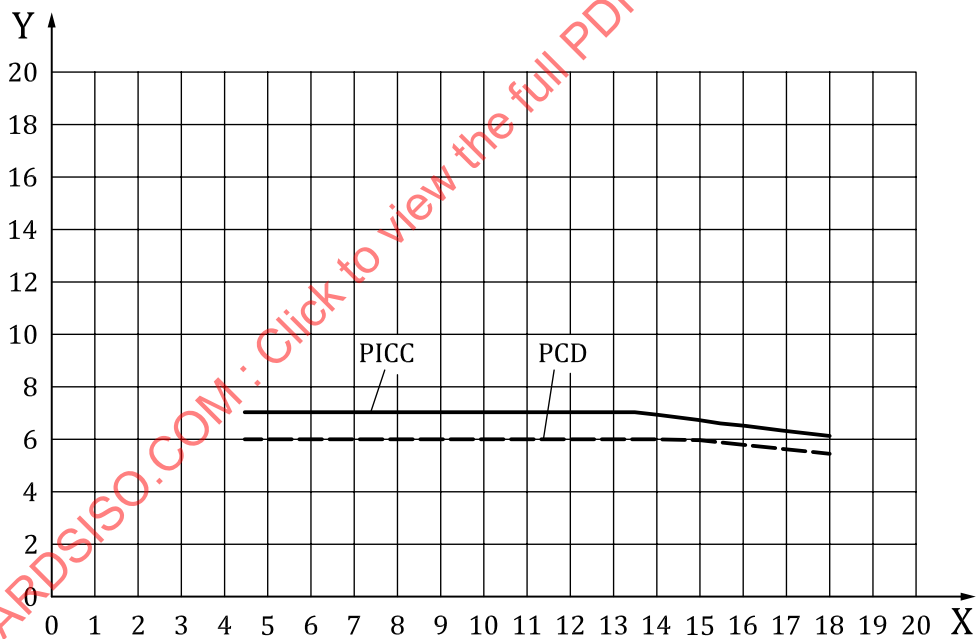

Key

- X field strength [A/m (rms)]
- Y load modulation amplitude [mV (peak)]

Figure 20 — Minimum load modulation amplitude for "Class 6"

8.2.5.2 Phase requirements

The PCD shall be able to receive a PICC response with the following characteristics,

- $\varnothing_{LM, INTRA}$ up to $\varnothing_{LM, INTRA, max, PCD} = 45^\circ$,
- $\varnothing_{LM, INTER}$ up to $\varnothing_{LM, INTER, max, PCD} = 35^\circ$,

- any initial value of $\varnothing_{LM, INIT}$.

The PCD shall provide f_c with a phase drift that does not vary more than $\pm 5^\circ$ during any supported PICC frame duration with respect to its initial phase at the very beginning.

8.2.6 Bit representation and coding

8.2.6.1 Bit representation and coding for a bit rate of $f_c/128$

The following sequences are defined:

- sequence D: the carrier shall be modulated with the subcarrier for the first half (50 %) of the bit duration, starting with MS1;
- sequence E: the carrier shall be modulated with the subcarrier for the second half (50 %) of the bit duration, starting with MS1;
- sequence F: the carrier is not modulated with the subcarrier for one bit duration.

Bit coding shall be Manchester with the following definitions:

- logic "1": sequence D;
- logic "0": sequence E;
- start of communication: sequence D;
- end of communication: sequence F;
- no information: no subcarrier.

8.2.6.2 Bit representation and coding for bit rates of $f_c/64, f_c/32, f_c/16, f_c/8, f_c/4,$ and $f_c/2$

Bit coding shall be NRZ-L with the following definitions:

- logic "1": the carrier shall be modulated with the subcarrier for one bit duration;
- logic "0": the carrier shall be modulated with the inverted subcarrier for one bit duration;
- start of communication: burst of 32 subcarrier cycles (phase as logic "1") followed by inverted subcarrier for one bit duration (phase as logic "0");
- end of communication: the carrier is not modulated with the subcarrier for one bit duration;
- no information: the carrier is not modulated with the subcarrier.

9 Communication signal interface Type B

9.1 Communication PCD to PICC

9.1.1 Bit rate

The bit rate for the transmission during initialization and anticollision shall be nominally $f_c/128$ (~106 kbit/s).

The bit rate for the transmission after initialization and anticollision shall be one of the following:

- $f_c/128$ (~106 kbit/s);
- $f_c/64$ (~212 kbit/s);
- $f_c/32$ (~424 kbit/s);
- $f_c/16$ (~848 kbit/s);
- $f_c/8$ (~1,70 Mbit/s);
- $f_c/4$ (~3,39 Mbit/s);
- $f_c/2$ (~6,78 Mbit/s).

Bit boundary tolerances and character separation shall be as defined in ISO/IEC 14443-3:2018, 7.1.1 and 7.1.2, respectively.

9.1.2 Modulation for bit rates of $f_c/128$, $f_c/64$, $f_c/32$, $f_c/16$, $f_c/8$, $f_c/4$, and $f_c/2$

Communication from PCD to PICC shall use the modulation principle of ASK 10 % of the RF operating field.

The modulation waveform shall comply with Figure 21. The rising and falling edges of the modulation shall be monotonic. The rise and fall times (t_r , t_f) shall be measured between 10 % and 90 % of the actual modulation step.

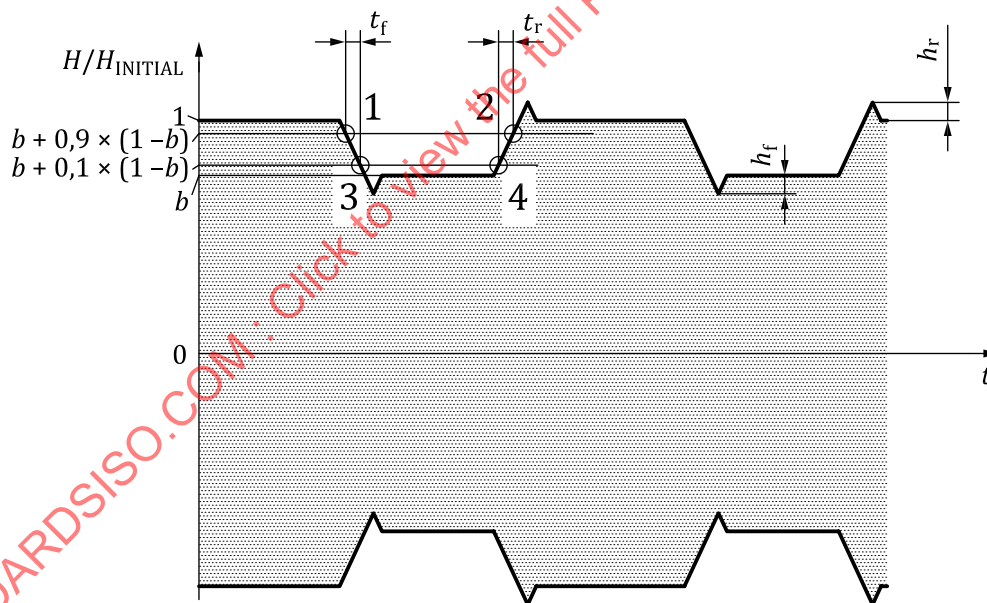

Key

- 1 start of t_f
- 2 end of t_r
- 3 end of t_f
- 4 start of t_r

Figure 21 — Type B modulation waveform

The PCD shall generate for any bit combination a modulation waveform with a modulation index, m

- greater than 8 % for all supported bit rates, and

- less than
 - 14 % for bit rates of $f_c/128$, $f_c/64$, $f_c/32$, and $f_c/16$,
 - 20 % for bit rates of $f_c/8$, $f_c/4$, and $f_c/2$.

The PICC shall be able to receive for any bit combination a modulation waveform with a modulation index, m

- greater than
 - both $(9,5 - 1,5 H/H_{\min})$ % and 7 % for bit rates of $f_c/128$, $f_c/64$, $f_c/32$, and $f_c/16$,
 - 8 % for bit rates of $f_c/8$, $f_c/4$, and $f_c/2$;
- and less than
 - 15 % for bit rates of $f_c/128$, $f_c/64$, $f_c/32$, and $f_c/16$,
 - 21 % for bit rates of $f_c/8$, $f_c/4$, and $f_c/2$.

NOTE 1 The minimum and maximum values of H are defined in [Table 1](#) and [Table 2](#).

The limits for the modulation index, m , for bit rates of $f_c/128$, $f_c/64$, $f_c/32$, and $f_c/16$ are illustrated in [Figure 22](#).

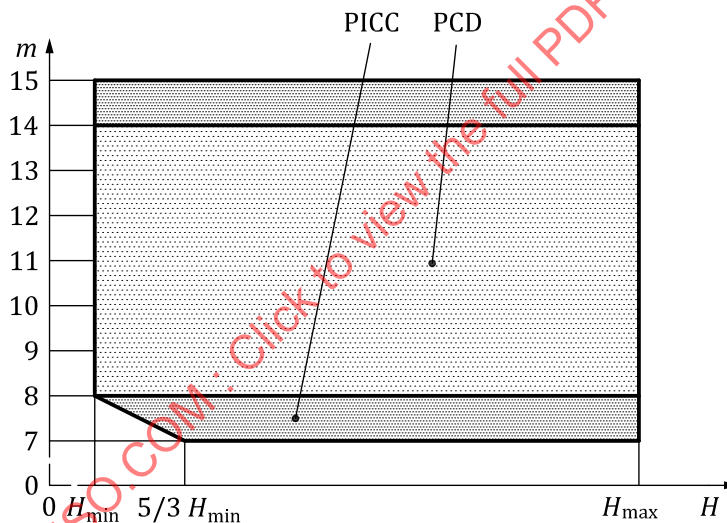

Key
 m [%]
 H [A/m (rms)]

Figure 22 — Type B modulation index m for bit rates of $f_c/128$, $f_c/64$, $f_c/32$, and $f_c/16$

The overshoot and undershoot of the PCD modulation waveform shall remain within limits specified in [Table 25](#).

Table 25 — PCD transmission: overshoot and undershoot for all supported bit rates

Parameter	Minimum	Maximum
h_f	0	$[1 - t_f / (2 \times t_{f, \max, \text{PCD}})] \times 0,10 \times (1 - b)$
h_r	0	$[1 - t_r / (2 \times t_{r, \max, \text{PCD}})] \times 0,10 \times (1 - b)$

NOTE 2 The maximum value of h_f / h_r is a function of the measured value of t_f / t_r and of $t_{f, \max, \text{PCD}} / t_{r, \max, \text{PCD}}$ (see requirements above [Figure 23](#), [Figure 24](#), [Figure 25](#), or [Figure 26](#)).

The PICC shall be able to receive a modulation waveform with overshoot and undershoot defined in [Table 26](#).

Table 26 — PICC reception: overshoot and undershoot for all supported bit rates

Parameter	Minimum	Maximum
h_f	0	$[1 - t_f / (2 \times t_{f, \max, \text{PICC}})] \times 0,11 \times (1 - b)$
h_r	0	$[1 - t_r / (2 \times t_{r, \max, \text{PICC}})] \times 0,11 \times (1 - b)$

NOTE 3 The maximum value of h_f / h_r is a function of the set value of t_f / t_r and of $t_{f, \max, \text{PICC}} / t_{r, \max, \text{PICC}}$ (see requirements above [Figure 23](#), [Figure 24](#), [Figure 25](#), or [Figure 26](#)).

For a bit rate of $f_c/128$, the PCD shall generate a modulation waveform with

- a fall time, t_f , between $0/f_c$ and $t_{f, \max, \text{PCD}} = 16/f_c$, and
- a rise time, t_r
 - greater than both $0/f_c$ and $t_f - 8/f_c$, and
 - less than both $t_f + 8/f_c$ and $t_{r, \max, \text{PCD}} = 16/f_c$.

For a bit rate of $f_c/128$, the PICC shall be able to receive a modulation waveform with

- a fall time, t_f , between $0/f_c$ and $t_{f, \max, \text{PICC}} = 17/f_c$, and
- a rise time, t_r
 - greater than both $0/f_c$ and $t_f - 9/f_c$, and
 - less than both $t_f + 9/f_c$ and $t_{r, \max, \text{PICC}} = 17/f_c$.

The timing parameters for PCD and PICC are illustrated in [Figure 23](#).

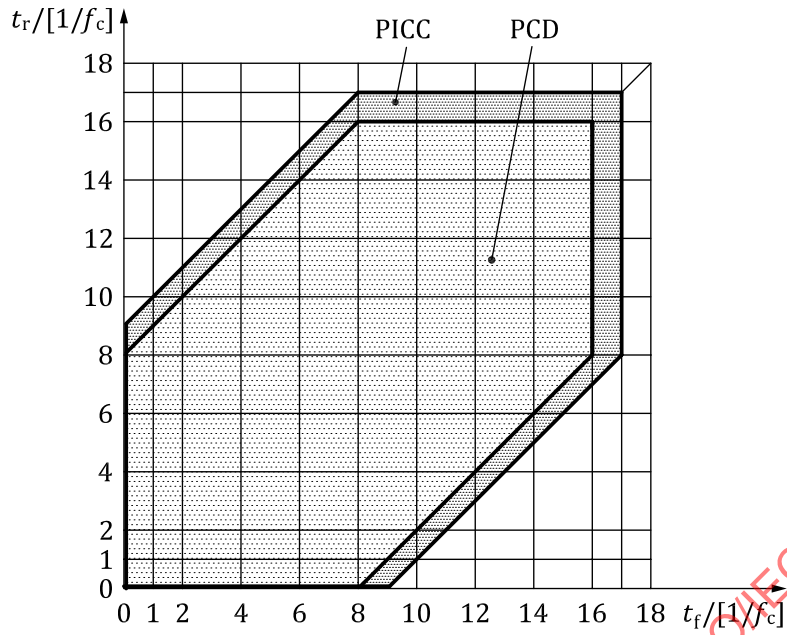

Figure 23 — Type B modulation waveform timing parameters for a bit rate of $f_c/128$

For a bit rate of $f_c/64$, the PCD shall generate a modulation waveform with

- a fall time, t_f , between $0/f_c$ and $t_{f, \max, PCD} = 14/f_c$, and
- a rise time, t_r
 - greater than both $0/f_c$ and $t_f - 6/f_c$, and
 - less than both $t_f + 6/f_c$ and $t_{r, \max, PCD} = 14/f_c$.

For a bit rate of $f_c/64$, the PICC shall be able to receive a modulation waveform with

- a fall time, t_f , between $0/f_c$ and $t_{f, \max, PICC} = 14/f_c$, and
- a rise time, t_r
 - greater than both $0/f_c$ and $t_f - 7/f_c$, and
 - less than both $t_f + 7/f_c$ and $t_{r, \max, PICC} = 14/f_c$.

The timing parameters for PCD and PICC are illustrated in [Figure 24](#).

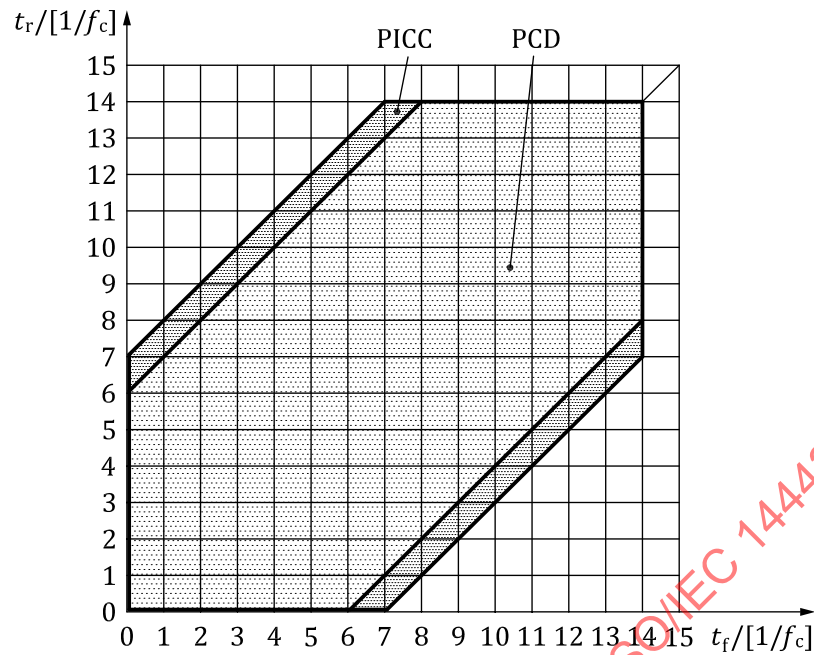

Figure 24 — Type B modulation waveform timing parameters for a bit rate of $f_c/64$

For a bit rate of $f_c/32$, the PCD shall generate a modulation waveform with

- a fall time, t_f , between $0/f_c$ and $t_{f, \max, \text{PCD}} = 11/f_c$, and
- a rise time, t_r
 - greater than both $0/f_c$ and $t_f - 4,5/f_c$, and
 - less than both $t_f + 4,5/f_c$ and $t_{r, \max, \text{PCD}} = 11/f_c$.

For a bit rate of $f_c/32$, the PICC shall be able to receive a modulation waveform with

- a fall time, t_f , between $0/f_c$ and $t_{f, \max, \text{PICC}} = 11/f_c$, and
- a rise time, t_r
 - greater than both $0/f_c$ and $t_f - 5,5/f_c$, and
 - less than both $t_f + 5,5/f_c$ and $t_{r, \max, \text{PICC}} = 11/f_c$.

The timing parameters for PCD and PICC are illustrated in [Figure 25](#).